

NELCOR

OPERATOR'S MANUAL
N-395 Pulse Oximeter

MALLINCKRODT

Caution: Federal law (U.S.) restricts this device to sale by or on the order of a physician.

CONTENTS

Figures
Tables

Contents	iii
Figures.....	vii
Tables.....	viii
Safety Information	1
General Safety Information.....	1
Introduction	3
Intended Use	3
General Operating Principles and Conditions	3
Controls, Indicators, And Symbols	5
Displays, Controls, Indicators, and Connectors.....	5
N-395 Symbols	6
Description of Controls	7
Function Buttons	7
Description of Displays and Visual Indicators.....	8
Description of Audible Indicators	9
Setup	11
Unpacking and Inspection	11
Performance Verification	11
List Of Components.....	11
Optional Accessories	12
Monitor Setup	18
General Warnings	18
Connecting The N-395 To AC Power.....	19
Operating on a Discharged Battery.....	19
Language Selection	21
Sensors	23
Selecting a Sensor.....	23
Biocompatibility Testing	24
Performance Considerations	25
Start-Up and Use	27
Basic Operation	27
Power-On Self-Test (POST)	28
Adult-Pediatric and Neonatal Settings	30
Contrast.....	31
Monitoring Mode	31
Pulse Search	32

Contents

At Initial Power-Up (Sensor Attached to Monitor)	32
At Initial Power-Up (No Sensor Attached to Monitor)	32
After Taking Measurements	33
Sensor Disconnected	33
Sensor Off	33
Automatic Shutdown	33
Alarms	34
Description of Alarms	34
<i>Satseconds</i> Alarm Management	35
<i>Satseconds</i> "Safety Net"	37
Determining the <i>Satseconds</i>	37
<i>Satseconds</i> Display	38
Adjustable Settings	38
Pulse Beep Volume	38
Alarm Volume	39
Alarm Silence Duration	39
Disabling Audible Alarms	40
Alarm Silence Reminder	40
Menu	41
Menu Structure	41
Limits	42
Overview	42
Viewing Current Alarm Limits	42
Changing Alarm Limits	43
Alarm Limits Changed Indicator	46
Trend	46
View	48
Zoom	50
40-Second Trends Table	50
Next	51
Delete	51
Print	51
Setup	52
View	52
Clock	52
Comm	53
Lang	57
Ncall	58
Analog	58
Light	58

Default Settings.....	58
Nurse Call Feature.....	60
Battery Operation.....	61
Low Battery Indicator.....	61
Disposal Of Device Components.....	62
Performance Considerations.....	62
Impact of Patient Conditions on Monitor Readings.....	62
Troubleshooting And Maintenance.....	65
Troubleshooting.....	65
Error Codes.....	65
Other Messages.....	66
Suggested Corrective Actions.....	67
EMI (Electromagnetic Interference).....	70
Obtaining Technical Assistance.....	71
Returning the N-395.....	71
Maintenance.....	71
Service.....	71
Periodic Safety Checks.....	72
Performance Verification.....	72
Cleaning.....	72
Specifications.....	73
Performance.....	73
Measurement Range.....	73
Accuracy.....	73
Electrical.....	74
Instrument.....	74
Battery.....	74
Environmental Conditions.....	75
Transport And Storage (in Shipping Container).....	75
Transport And Storage (Not in Shipping Container).....	75
Operation.....	75
Physical Characteristics.....	75
Compliance.....	76
Quick Guide to Operation.....	77
Introduction.....	77
Settings Adjustments.....	77
Principles of Operation.....	83
Oximetry Overview.....	83
Automatic Calibration.....	83
Functional versus Fractional Saturation.....	84

Contents

Measured versus Calculated Saturation.....	84
<i>Data Port Protocol</i>	87
Overview	87
Connecting to the Data Port.....	87
Baud Rate	89
Setting Data Port Protocol.....	89
Real-Time Display Format	90
Column Headings	91
Patient Data and Operating Status	93
Trend Data Printout (ASCII Mode).....	94
Trend Data Printout (Graph Mode)	95
Nurse Call	95
Analog Outputs	97
<i>Index</i>	99

FIGURES

Figure 1:	N-395 Front Panel Display (Pleth View)	5
Figure 2:	N-395 Rear Panel.....	6
Figure 3:	GCX Mounting Plate.....	13
Figure 4:	GCX Poly-mount (vertical wall mount with 19-inch channel)	14
Figure 5:	GCX Poly-mount (horizontal wall mount with rail adapter).....	15
Figure 6:	GCX Roll Stand Poly-mount.....	16
Figure 7:	GCX Utility Basket.....	17
Figure 8:	Soft Sided Carrying Case	18
Figure 9:	Monitoring Mode Display - Pleth View.....	30
Figure 10:	Monitoring Mode Display – Blip (Magnified) View	30
Figure 11:	Alarm Response with SatSeconds	36
Figure 12:	Alarm Limits Selection.....	46
Figure 13:	SpO2 Trend.....	47
Figure 14:	Dual Trend Display.....	48
Figure 15:	SpO2 Trend Display	49
Figure 16:	Pulse Rate Trend Display.....	49
Figure 17:	Histogram	50
Figure 18:	AMP Trend Display	50
Figure 19:	40-Second Trends.....	51
Figure 20:	SpaceLabs Connection	55
Figure 21:	Oxyhemoglobin Dissociation Curve	85
Figure 22:	Data Port Pin Layout	89
Figure 23:	Real-Time Printout	91
Figure 24:	Trend Data Printout (ASCII MODE)	95
Figure 25:	Trend Data Printout (GRAPH MODE).....	95

Contents

TABLES

Table 1: Nellcor Sensors.....	24
Table 2: Limits Menu.....	43
Table 3: Trend Menu.....	44
Table 4: Setup Menu.....	45
Table 5: Trend Scale.....	47
Table 6: Factory Default Settings (Adult)	59
Table 7: Factory Default Settings (Neonate).....	60
Table 8: Error Codes and Messages	66
Table 9: Settings Adjustments	77
Table 10: Data Port Pinouts	88
Table 11: Status Codes	94
Table 12: Voltage Between Pins 10 and 11	96
Table 13: Analog Pinouts	97

SAFETY INFORMATION

General Safety Information

GENERAL SAFETY INFORMATION

This section contains important safety information related to general use of the N-395 pulse oximeter. Other important safety information appears throughout the manual in sections that relate specifically to the precautionary information. Read all text surrounding all precautionary information.

Important! Before use, carefully read this manual, accessory directions for use, all precautionary information in boldface type, and specifications.

WARNING: Explosion hazard. Do not use the N-395 pulse oximeter in the presence of flammable anesthetics or gases.

WARNING: The N-395 is a prescription device and is to be operated by qualified personnel only.

WARNING: Pulse oximetry readings and pulse signal can be affected by certain ambient environmental conditions, sensor application errors, and certain patient conditions. See the appropriate sections of the manual for specific safety information.

WARNING: Chemicals from a broken LCD display panel are toxic when ingested. Use caution when handling a monitor with a broken display panel.

Caution: When connecting the N-395 to any instrument, verify proper operation before clinical use. Both the N-395 and the instrument connected to it must be connected to a grounded outlet. Accessory equipment connected to the monitor's data interface must be certified according to IEC Standard 950 for data-processing equipment or IEC Standard 601-1 for electromedical equipment. All

Safety Information

combinations of equipment must be in compliance with IEC Standard 601-1-1 systems requirements. Anyone who connects additional equipment to the signal input port or signal output port (N-395 data port connector) configures a medical system and is therefore responsible for ensuring that the system complies with the requirements of system standard IEC Standard 601-1-1 and the electromagnetic compatibility system standard IEC Standard 601-1-2. The N-395 accuracy may degrade if it is connected to secondary I/O devices when the instrument is not connected to earth reference.

To ensure accurate readings, consider the environmental conditions that are present and the condition of the patient. See the appropriate sections of the manual for specific safety information related to these conditions.

INTRODUCTION

Intended Use
General Operating Principles and Conditions

The latest version of this manual is available on the Internet at:
http://www.mallinckrodt.com/respiratory/resp/Serv_Supp/ProductManuals.html

INTENDED USE

The N-395 is a portable pulse oximeter intended for use as a continuous non-invasive monitor of functional oxygen saturation of arterial hemoglobin (SpO₂) and pulse rate. The intended patient population comprises adult, pediatric, and neonatal patients. The intended environments of use are hospitals, hospital-type facilities, intra-hospital transport environments, and home care. The N-395 is for prescription use only. Hospital use typically covers such areas as general care floors, operating rooms, special procedure areas, intensive and critical care areas, within the hospital plus hospital-type facilities such as surgicenters, sub-acute centers, special nursing facilities, and sleep labs, outside of the hospital. Intra-hospital transport includes transport of a patient within the hospital or hospital-type facility.

WARNING: The N-395 is intended only as an adjunct in patient assessment. It must be used in conjunction with clinical signs and symptoms.

GENERAL OPERATING PRINCIPLES AND CONDITIONS

The N-395 uses pulse oximetry to measure functional oxygen saturation in the blood. Pulse oximetry works by applying a sensor to a pulsating arteriolar vascular bed, such as a finger or toe. The sensor contains a dual light source and a photodetector.

Introduction

Bone, tissue, pigmentation, and venous vessels normally absorb a constant amount of light over time. The arteriolar bed normally pulsates and absorbs variable amounts of light during the pulsations. The ratio of light absorbed is translated into a measurement of functional oxygen saturation (SpO₂).

Note: For an explanation of functional versus fractional saturation, refer to *Principles of Operation*.

Because a measurement of SpO₂ is dependent upon light from the sensor, excessive ambient light can interfere with this measurement.

Specific information about ambient environmental conditions, sensor application, and patient conditions is contained throughout this manual.

CONTROLS, INDICATORS, AND SYMBOLS

Displays, Controls, Indicators, and Connectors

N-395 Symbols

Description of Controls

Description of Displays and Visual Indicators

Description of Audible Indicators

DISPLAYS, CONTROLS, INDICATORS, AND CONNECTORS

Figure 1 and Figure 2 show the front and rear views of the N-395 and identify displays, controls, and connectors.

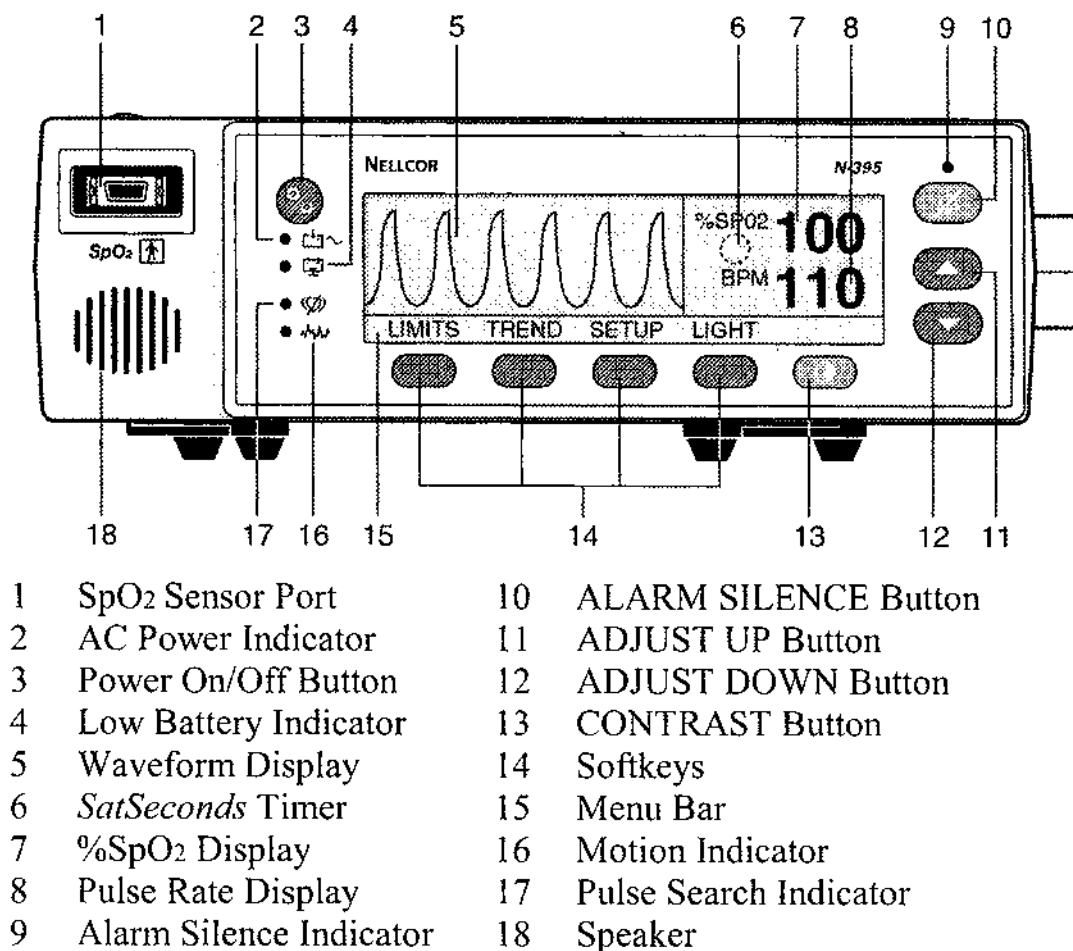
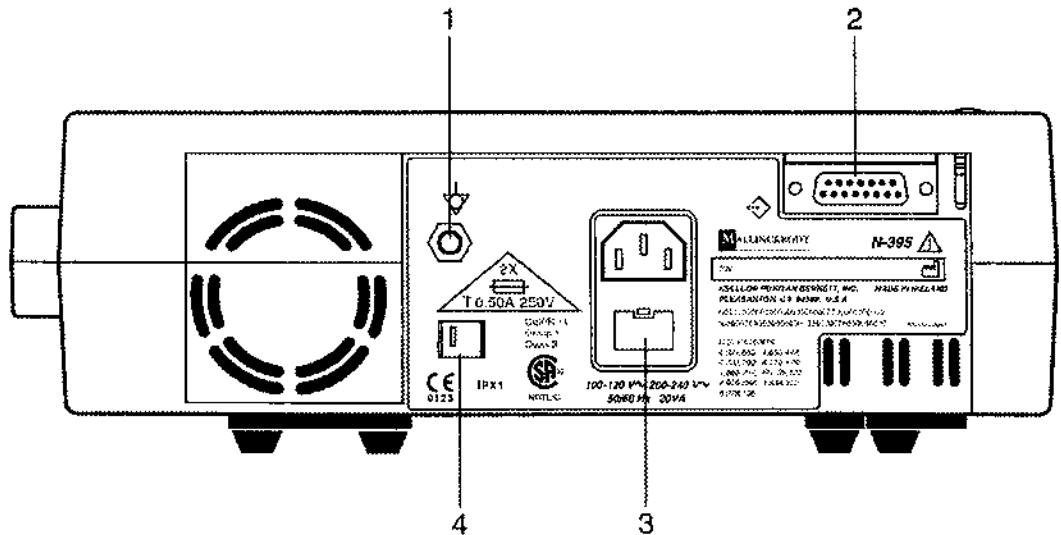

Figure 1: N-395 Front Panel Display (Pleth View)



- | | |
|------------------------------------|-----------------------------------|
| 1. Equipotential (ground) Terminal | 3. Fuse Receptacle |
| 2. Data Port Connector | 4. Supply Voltage Selector Switch |

Figure 2: N-395 Rear Panel

N-395 SYMBOLS



See Instructions for Use

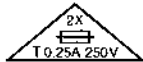

Fuse Replacement



Equipotential Terminal



Type BF Applied Part - Not defibrillator proof



Date of Manufacture



Data Interface

DESCRIPTION OF CONTROLS

Function Buttons



The Power On/Off Button. Used to turn the N-395 monitor on or off.



The ALARM SILENCE Button. Used to silence current alarms for the alarm silence duration period. When an alarm has been silenced, pressing the button again reactivates, or “unsilences,” the alarm. It is also used to view and adjust alarm silence duration and alarm volume. The ALARM SILENCE button clears “Sensor Off” and “Sensor Disconnect” messages from the display.



The ADJUST UP Button. Used to increase alarm limit values, alarm silence duration, pulse beep volume, alarm volume, contrast, date and time values, data port baud rate, and to move the cursor to the right (in the trend view).



The ADJUST DOWN Button. Used to decrease alarm limit values, alarm silence duration, pulse beep volume, alarm volume, contrast, date and time values, data port baud rate, and to move the cursor to the left (in the trend view).



The CONTRAST Button. Used in conjunction with the ADJUST UP/DOWN Buttons to lighten or darken the display screen.



The softkey buttons have multiple uses depending on the legend displayed above the button.

DESCRIPTION OF DISPLAYS AND VISUAL INDICATORS

%SP02 100 The %SpO₂ Display. Shows the saturation of hemoglobin oxygen. The displayed value flashes zeros during loss-of-pulse alarms and flashes the SpO₂ value when SpO₂ is outside of the alarm limits. During Pulse Search, the monitor continues to update the display. If alarm limits have been changed from their power-on defaults, a decimal point (.) is displayed after the SpO₂ value (100.).



The Pulse Amplitude Indicator (blip bar). Indicates pulse beat and shows the relative pulse amplitude. As the detected pulse becomes stronger, more bars light with each pulse. This indicator is available only in the blip (magnified) view. The displayed value flashes zeros during loss-of-pulse alarms and flashes the pulse rate value when pulse rate is outside of the alarm limits. During Pulse Search, the monitor continues to update the display. If alarm limits have been changed from their power-on defaults, a decimal point (.) is displayed after the pulse rate value (95.).

BPM 86 The Pulse Rate Display. Shows the pulse rate in beats per minute. It flashes during loss-of-pulse alarms and when the pulse rate is outside of the alarm limits. During Pulse Search, the monitor continues to update the display.



The AC Power Indicator. Lights continuously when the N-395 is connected to AC power. It also indicates that the battery is charging. It is off when the monitor is being powered by its internal battery.



The Low Battery Indicator. Lights continuously to indicate that 15 or fewer minutes of battery capacity remains.



The Alarm Silence Indicator. Lights continuously when an audible alarm has been silenced. It flashes when the alarm silence duration has been set to OFF.



The Motion Indicator. Lights when the monitor detects motion artifact.



The Pulse Search Indicator. Lights continuously prior to initial acquisition of a pulse signal, and during prolonged and challenging monitoring conditions. It flashes during a loss-of-pulse signal.

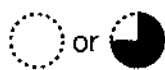

The SatSeconds™ Indicator. Fills in clockwise as the SatSeconds alarm management system approaches the *SatSeconds* alarm limit threshold.

DESCRIPTION OF AUDIBLE INDICATORS

Following are descriptions of N-395 audible indicators.

Power-On Self-Test Pass	A 1-second tone indicating that the N-395 has been turned on and successfully completed the power-on self-test
Valid Button Press	A short, medium-pitched tone indicating that an appropriate button has been pressed
Invalid Button Press	A short, low-pitched tone indicating that a button has been pressed that is not appropriate for the current state of the monitor
High Priority Alarm	A high-pitched, fast-pulsing tone indicating loss of pulse
Medium Priority Alarm	A medium-pitched, pulsing tone indicating an SpO ₂ or pulse rate limit violation

Controls, Indicators, and Symbols

Low Priority Alarm	A low-pitched, slow-pulsing tone indicating a sensor disconnect, sensor off, low battery, or monitor failure
Alarm Silence Reminder	Three beeps that sound approximately every 3 minutes when alarms are silenced with the alarm silence duration set to OFF
Pulse Beep	A single beep sounds for each detected pulse. The pitch changes as monitored SpO ₂ values increase or decrease.
Volume Setting Tone	A continuous tone that is used to adjust the alarm volume
Confirmation Tone	Three beeps sound to indicate that default settings have been saved or reset to factory defaults or trend data has been deleted

SETUP

Unpacking and Inspection
Performance Verification
List of Components
Monitor Setup
Language Selection

UNPACKING AND INSPECTION

Notify the carrier if the shipping carton is damaged. Unpack the N-395 and components. If anything is missing or damaged, contact Mallinckrodt Technical Services Department or your local Mallinckrodt representative.

PERFORMANCE VERIFICATION

The N-395 performance can be verified by following the procedures outlined in the *Performance Verification* section of the N-395 service manual. Qualified service personnel should perform this procedure before using the monitor for the first time in a clinical setting.

LIST OF COMPONENTS

- 1 N-395 Pulse Oximeter
- 1 Nellcor[®] sensor or assortment pack
- 1 SCP-10 or MC-10 Pulse Oximeter Sensor Cable
- 1 N-395 Operator's Manual
- 1 Hospital Grade Power Cord
- 2 Fuses

Optional Accessories

Several mounting configurations, a utility basket, and a carrying case are offered with the N-395. Contact Mallinckrodt's Technical Services Department or your local Mallinckrodt representative for information about these accessories.

- GCX Mounting Plate. See Figure 3, page 13.
- GCX Poly-mount (vertical wall mount with 19-inch channel). See Figure 4, page 14.
- GCX Poly-mount (horizontal wall mount with rail adapter). See Figure 5, page 15.
- GCX Roll Stand Poly-mount. See Figure 6, page 16.
- GCX Utility Basket. See Figure 7, page 17.
- Soft Sided Carrying Case. See Figure 8, page 18.

GCX Mounting Plate

An optional mounting plate is available from Mallinckrodt for the N-395. This mounting plate fits standard, commercially available GCX mount brackets, and is used to securely mount the monitor to a wall or roll stand.

The plate attaches to the bottom of the N-395 monitor as shown in Figure 3. For further instructions regarding connecting the plate to GCX brackets, refer to the illustrated directions for use included with the GCX mounting plate.

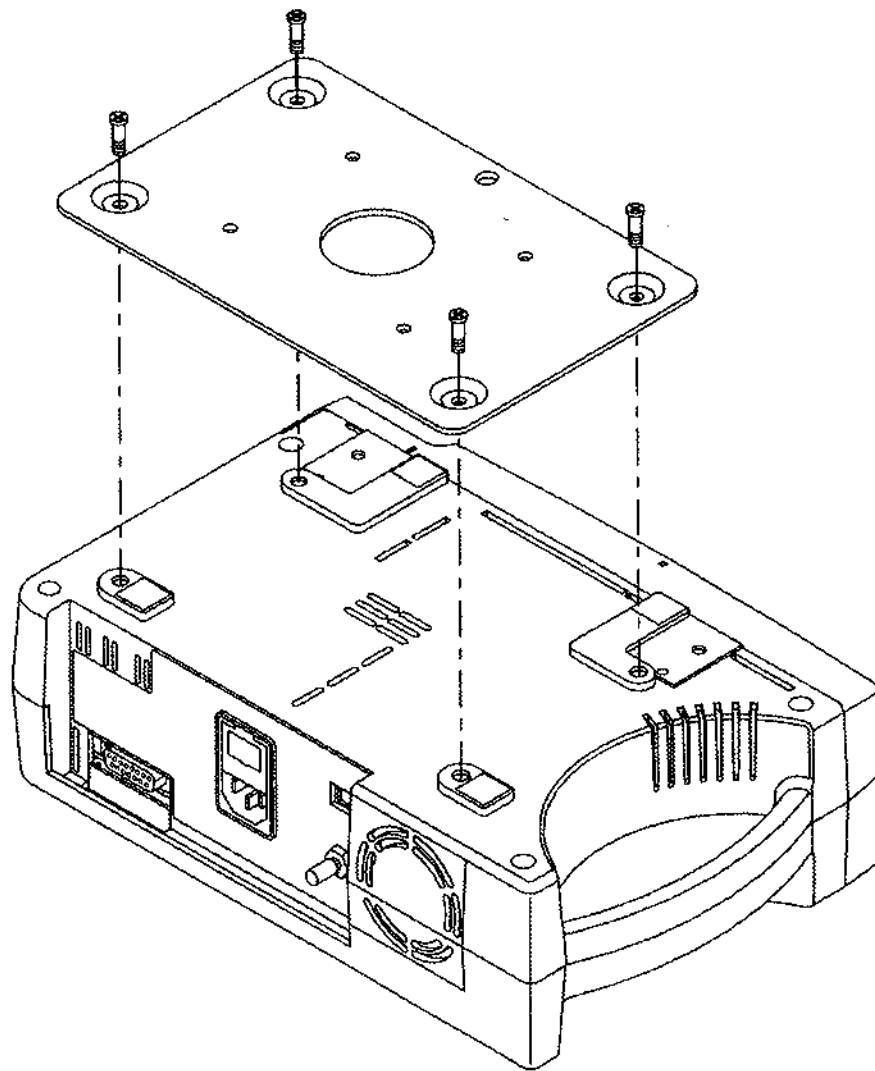

Figure 3: GCX Mounting Plate

GCX Poly-mount (vertical wall mount with 19-inch channel)

An optional vertical wall mount with 19-inch channel is available from Mallinckrodt for the N-395.

The vertical wall mount with 19-inch channel attaches to the N-395 monitor GCX mounting plate as shown in Figure 4. For further instructions regarding connecting the vertical wall mount with 19-inch channel, refer to the illustrated directions for use included with the vertical wall mount with 19-inch channel.

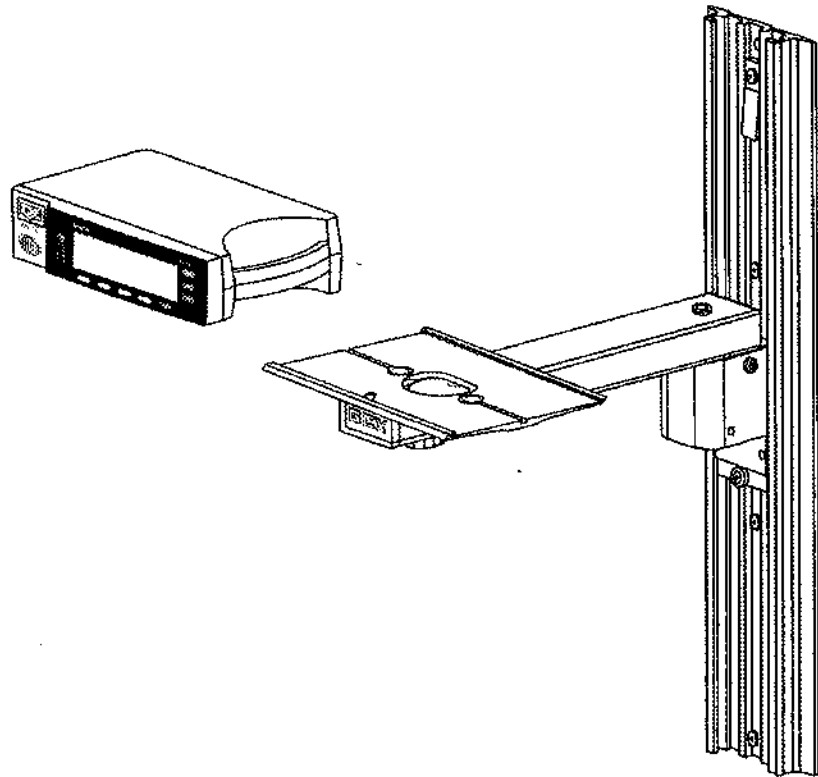

Figure 4: GCX Poly-mount (vertical wall mount with 19-inch channel)

GCX Poly-mount (horizontal wall mount with rail adapter)

An optional horizontal wall mount with rail adapter is available from Mallinckrodt for the N-395.

The horizontal wall mount with rail adapter attaches to the N-395 monitor GCX mounting plate as shown in Figure 5. For further instructions regarding connecting the horizontal wall mount with rail adapter, refer to the illustrated directions for use included with horizontal wall mount with rail adapter.

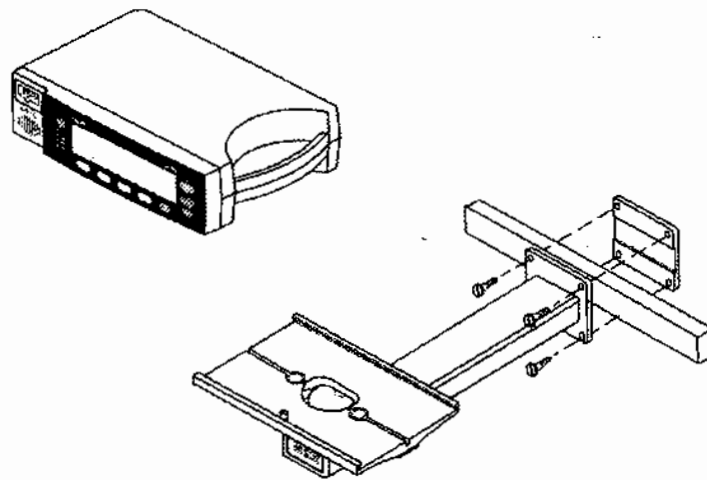

Figure 5: GCX Poly-mount (horizontal wall mount with rail adapter)

Setup

GCX Roll Stand Poly-mount

An optional GCX roll stand poly-mount is available from Mallinckrodt for the N-395.

The GCX roll stand poly-mount attaches to the N-395 monitor GCX mounting plate as shown in Figure 6. For further instructions regarding connecting the GCX roll stand poly-mount, refer to the illustrated directions for use included with GCX roll stand poly-mount.

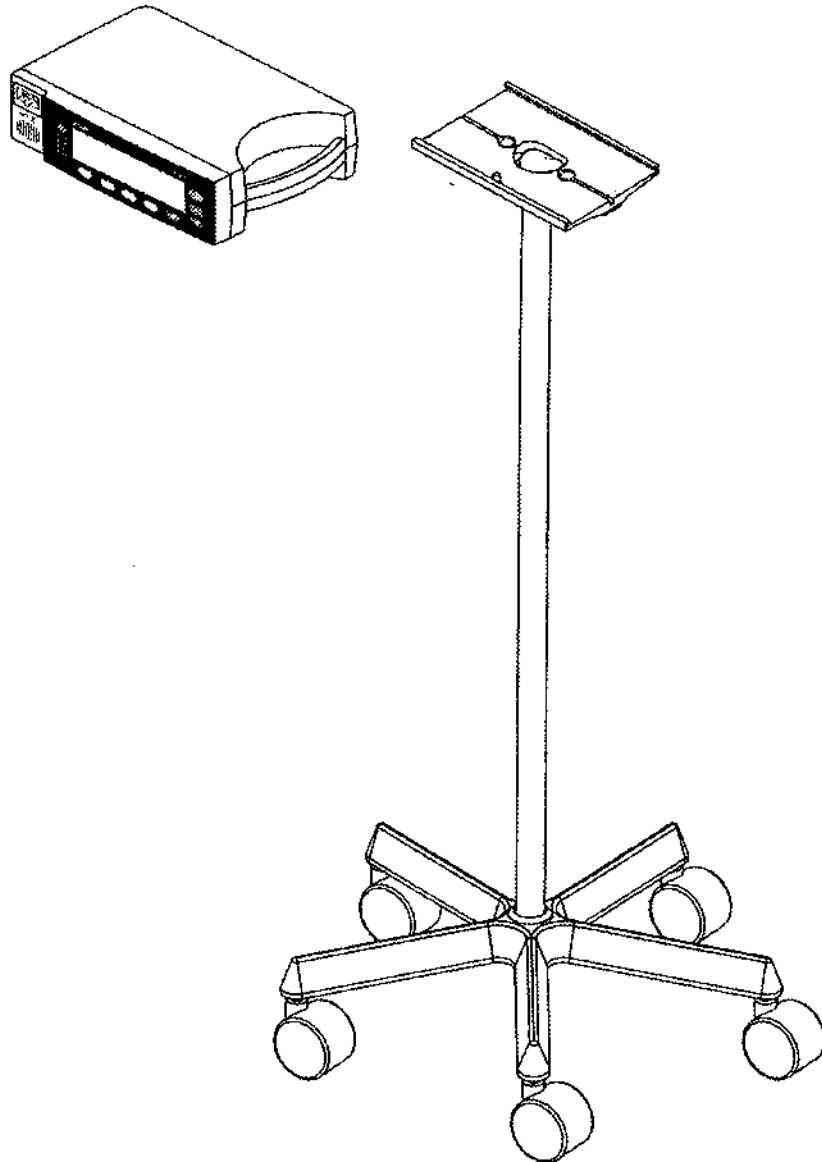

Figure 6: GCX Roll Stand Poly-mount

GCX Utility Basket

An optional GCX utility basket is available from Mallinckrodt for the N-395.

The GCX utility basket attaches to the GCX roll stand polymount as shown in Figure 7. For further instructions regarding connecting the GCX utility basket, refer to the illustrated directions for use included with GCX utility basket.

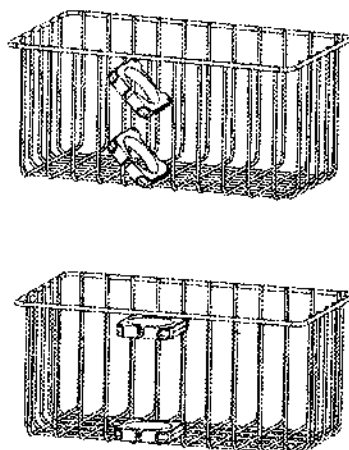

Figure 7: GCX Utility Basket

Soft-Sided Carrying Case

An optional soft-sided carrying case is available from Mallinckrodt for the N-395. See Figure 8. The padded carrying case protects the N-395 while transporting the monitor. The carrying case contains two pockets for sensors, cables, and operator's manual.

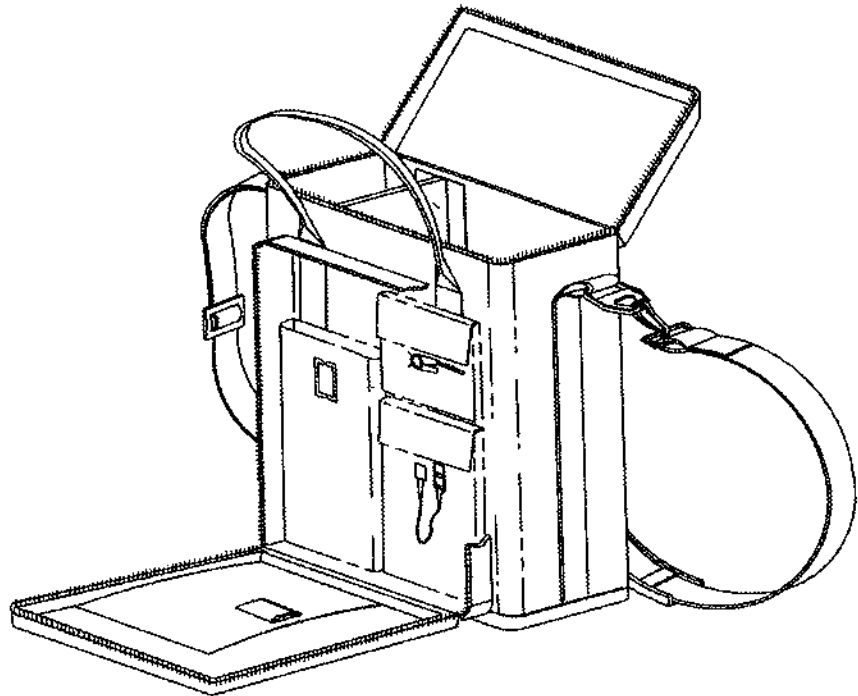

Figure 8: Soft Sided Carrying Case

MONITOR SETUP

General Warnings

WARNING: To ensure patient safety, do not place the monitor in any position that might cause it to fall on the patient.

WARNING: As with all medical equipment, carefully route patient cabling to reduce the possibility of patient entanglement or strangulation.

WARNING: Disconnect the N-395 and Nellcor sensor from the patient during magnetic resonance imaging (MRI) scanning. Induced current could potentially cause burns. The N-395 may affect the MRI image and the MRI unit may affect the accuracy of oximeter measurements.

WARNING: To ensure accurate performance and prevent device failure, do not subject the N-395 to extreme moisture, such as direct exposure to rain. Such exposure may cause inaccurate performance or device failure.

WARNING: Do not use an N-395 monitor, sensor, cables, or connectors that appear to be damaged.

WARNING: The N-395 is not defibrillator-proof. However, it may remain attached to the patient during defibrillation or while an electrosurgical unit is in use, but the readings may be inaccurate during use and shortly thereafter.

Connecting the N-395 to AC Power

The N-395 operates on AC power when the hospital-grade power cord is connected to both the monitor and an AC power source (wall outlet).

The supply voltage selector switch allows connection of the monitor to AC power ranging from 100 volts AC to 240 volts AC. The switch has two positions: one for 100 - 120 volts AC (“115”), and one for 200 - 240 volts AC (“230”). *Ensure that the supply voltage selector switch on the rear panel is set to the proper voltage.*

Operating on a Discharged Battery

The N-395 will not operate when its internal battery is completely discharged, even when the monitor is connected to AC power. Instead, the error code “EEE 04” will be displayed. This feature prevents the accidental use of the monitor with a dead battery. The monitor is only capable of indicating a loss of AC power if its internal battery is functional.

Setup

The battery may discharge during prolonged storage or shipment. If the monitor has been in storage for more than 2 months, it is important to plug the monitor into an AC outlet and allow the battery to charge for approximately 30 minutes before attempting to operate the instrument on AC power.

To charge a low battery, connect the monitor to AC power. A full charge of a completely discharged battery takes 14 hours while the monitor is turned off.

1. Place the N-395 on a flat surface near the patient. With the optional wall mount plate available from Mallinckrodt, the monitor may be attached to a GCX Poly-mount bracket.
2. Plug the female connector end of the power cord into the rear of the monitor. Use only the hospital-grade power cord provided by Mallinckrodt.
3. Plug the male connector end of the power cord into a properly grounded AC outlet.
4. Verify that the AC Power Indicator is lit. If it is not, ensure that the supply voltage selector switch matches your AC voltage source. If the indicator still does not light, contact qualified service personnel, your local Mallinckrodt representative, or the Mallinckrodt Technical Services Department.

WARNING: In the USA, do not connect the monitor to an electrical outlet controlled by a wall switch because the monitor may be accidentally turned off.

5. Select a Nellcor sensor appropriate for the patient to be monitored (see the *Sensors and Accessories* section of this manual for sensor selection information).

WARNING: Do not use a sensor cable with the N-395 monitor (other than the SCP-10 or MC-10 sensor cable). Use of another sensor cable will have an adverse effect on performance. Do not attach any cable that is intended for computer use to the sensor port. Do not connect any device other than a Nellcor approved sensor to the sensor connector.

6. Plug the sensor into the SCP-10 or MC-10 sensor cable, and secure the sensor in place by lowering the plastic sensor lock over the sensor connector until it clicks into place (refer to the SCP-10 or MC-10 directions for use).
7. Plug the SCP-10 or MC-10 cable into the sensor port located on the front of the N-395.

LANGUAGE SELECTION

The languages available for display on the screen are English, French, German, Dutch, Portuguese, Spanish, and Italian. The N-395 is shipped with the factory default English language displayed.

To select the appropriate language after the unit is powered on:

- press the SETUP softkey
- press the NEXT softkey
- press the LANG softkey
- Use the ADJUST UP and ADJUST DOWN Buttons to select the desired language
- Press the EXIT button to return to the main menu.

Service personnel may set the appropriate language as the power-on default using the procedure described in the N-395 service manual.

SENSORS

Selecting a Sensor
Biocompatibility Testing
Performance Considerations

SELECTING A SENSOR

WARNING: Before use, carefully read the sensor directions for use, including all warnings, cautions, and instructions.

WARNING: Do not use a damaged sensor or sensor cable. Do not use a sensor with exposed optical components.

WARNING: Use only Nellcor sensors and sensor cables with this monitor. Other sensors or sensor cables may cause improper N-395 performance.

WARNING: Do not use a sensor cable with the N-395 monitor (other than the SCP-10 or MC-10 sensor cable). Use of another sensor cable will have an adverse effect on performance. Do not attach any cable that is intended for computer use to the sensor port. Do not connect any device other than a *Nellcor*-approved sensor to the sensor connector.

WARNING: Tissue damage can be caused by incorrect application or duration of use of a SpO₂ sensor. Inspect the sensor site periodically as directed in the sensor directions for use.

When selecting a sensor, consider the patient's weight and activity level, the adequacy of perfusion, the available sensor sites, the need for sterility, and the anticipated duration of monitoring. For more information, refer to Table 1 or contact your local Mallinckrodt representative.

Table 1: Nellcor Sensors

Sensor	Model	Patient Size
Oxisensor® II oxygen transducers (Sterile, single-use only)	N-25/N-25LF I-20 D-20 D-25/D-25L R-15	<3 or >40 kg 3 to 20 kg 10 to 50 kg >30 kg >50 kg
Oxiband® oxygen transducer (Reusable with disposable nonsterile adhesive)	OXI-A/N OXI-P/I	<3 or >40 kg 3 to 40 kg
Oxi 1-2-3™ oxygen sensor (Multiuse, nonsterile)	Ox123-A/N Ox123-P/I	<3 or >40 kg 3 to 40 kg
Durasensor® oxygen transducer (Reusable, nonsterile)	DS-100A	>40 kg
Nellcor reflectance oxygen transducer (reusable, nonsterile)	RS-10	>40 kg
Dura-Y® multisite oxygen transducer (Reusable, nonsterile)	D-YS	>1 kg
For use with the Dura-Y sensor:		
Ear clip (Reusable, nonsterile)	D-YSE	>30 kg
Pedi-Check™ pediatric spot-check clip (Reusable, nonsterile)	D-YSPD	3 to 40 kg
OxiCliq® oxygen transducers (Sterile, single-use only)	P N I A	10 to 50 kg <3 or >40 kg 3 to 20 kg >30 kg

BIOCOMPATIBILITY TESTING

Biocompatibility testing has been conducted on Nellcor sensors in compliance with ISO 10993-1, Biological Evaluation of Medical Devices, Part 1: Evaluation and Testing. The sensors have passed the recommended biocompatibility testing and are therefore in compliance with ISO 10993-1.

PERFORMANCE CONSIDERATIONS

WARNING: Pulse oximetry readings and pulse signal can be affected by certain ambient environmental conditions, sensor application errors, and certain patient conditions.

Inaccurate measurements can be caused by:

- incorrect application of the sensor
- placement of the sensor on an extremity with a blood pressure cuff, arterial catheter, or intravascular line
- ambient light
- prolonged patient movement

Loss-of-pulse signal can occur for the following reasons:

- the sensor is too tight
- a blood pressure cuff is inflated on the same extremity as the one with the sensor attached
- there is arterial occlusion proximal to the sensor

Use only Nellcor sensors and sensor cables.

Select an appropriate sensor, apply it as directed, and observe all warnings and cautions presented in the directions for use accompanying the sensor. Clean and remove any substances such as nail polish from the application site. Periodically check to ensure that the sensor remains properly positioned on the patient.

WARNING: Tissue damage can be caused by incorrect application or duration of use of an SpO₂ sensor. Inspect the sensor site as directed in the sensor directions for use.

High ambient light sources such as surgical lights (especially those with a xenon light source), bilirubin lamps, fluorescent lights, infrared heating lamps, and direct sunlight can interfere with the performance of an SpO₂ sensor. To prevent interference from ambient light, ensure that the sensor is properly applied, and cover the sensor site with opaque material.

Sensors

Note: Failure to take this precaution in high ambient light conditions may result in inaccurate measurements.

If patient movement presents a problem, try one or more of the following remedies to correct the problem.

- verify that the sensor is properly and securely applied
- move the sensor to a less active site
- use an adhesive sensor that tolerates some patient motion
- use a new sensor with fresh adhesive backing

If poor perfusion affects performance, consider using the *Oxisensor R-15* sensor; it obtains measurements from the nasal septal anterior ethmoid artery, an artery supplied by the internal carotid. This sensor may obtain measurements when peripheral perfusion is relatively poor.

For low peripheral perfusion, consider using the Nellcor RS-10 sensor, which is applied to the forehead or temple. These are sites that may be spared during peripheral vasoconstriction.

Note: The preceding section pertains to patient and environmental conditions that can be addressed by sensor selection and application. For information regarding the impact of other patient environmental conditions on oximeter performance, see "Performance Considerations" in the *Start-Up and Use* section of this manual.

START-UP AND USE

Basic Operation
Alarms
Adjustable Settings
Menu
Limits
Trend
Setup
Battery Operation
Disposal of Device Components
Performance Considerations

BASIC OPERATION

WARNING: The N-395 is a prescription device and is to be operated by qualified personnel only.

WARNING: Do not lift the monitor by the sensor cable or power cord because the cable or cord could disconnect from the monitor, causing the monitor to drop on the patient.

WARNING: The N-395 is intended only as an adjunct in patient assessment. It must be used in conjunction with clinical signs and symptoms.

WARNING: Pulse oximetry readings and pulse signal can be affected by certain ambient environmental conditions, sensor application errors, and certain patient conditions. See the appropriate sections of the manual for specific safety information.

WARNING: Do not silence the audible alarm or decrease its volume if patient safety could be compromised.

WARNING: Each time the monitor is used, check alarm limits to ensure that they are appropriate for the patient being monitored.

Important! Prior to using the N-395, carefully read this manual, accessory directions for use, all precautionary information in boldface type, and all specifications.

Before using the N-395 in a clinical setting, verify that the monitor is working properly and is safe to use. Proper working condition can be verified by successful completion of the power-on self-test described in the following steps, and by following instructions contained in the "Monitoring Mode" paragraph of this section.

Ensure that the supply voltage selector switch on the rear panel matches the AC voltage at your location.

Power-On Self-Test (POST)

WARNING: Ensure that the speaker is clear of any obstruction. Failure to do so could result in an inaudible alarm tone.

1. Plug an appropriate Nellcor sensor firmly into the SCP-10 or MC-10 cable and lower the SCP-10 or MC-10 sensor lock over the sensor connector until it clicks into place. Insert the SCP-10 or MC-10 into the N-395 sensor port. Apply the sensor to the patient as described in the sensor directions for use.
2. Turn on the N-395 by pressing the POWER ON/OFF Button. The monitor automatically starts a power-on self-test (POST), which tests its circuitry.

3. During the POST, the entire display lights and then the Nellcor brand with model number and software version are displayed for approximately 3 seconds. All indicator lights illuminate briefly.

Caution: If any indicator or display element does not light, do not use the monitor. Instead, contact qualified service personnel, your local Mallinckrodt representative, or the Mallinckrodt Technical Services Department.

4. If the N-395 detects an internal problem during POST, an error code or error message may be displayed and a low priority alarm will sound. Depending on the reason for the failure, the screen may be blank or the low priority alarm may not sound. Refer to the *Troubleshooting* section for a list of correctable error messages.
5. Upon successful completion of the POST, the N-395 sounds a 1-second tone indicating that the monitor has passed the test.

WARNING: If you do not hear the POST pass tone, do not use the monitor.

6. If a sensor is connected to the monitor and the patient, the Pulse Search Indicator lights and the N-395 displays zeroes in the %SpO₂ and Pulse Rate Displays while it searches for a valid pulse. If a sensor is not attached to the monitor, dashes are displayed and the Pulse Search Indicator is not lit.

When a valid pulse is detected, the N-395 enters the Monitoring Mode and a display similar to the one indicated in either Figure 9 or Figure 10 is displayed.

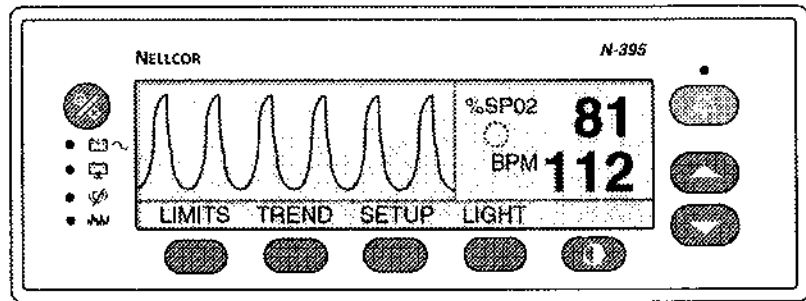

Figure 9: Monitoring Mode Display - Pleth View

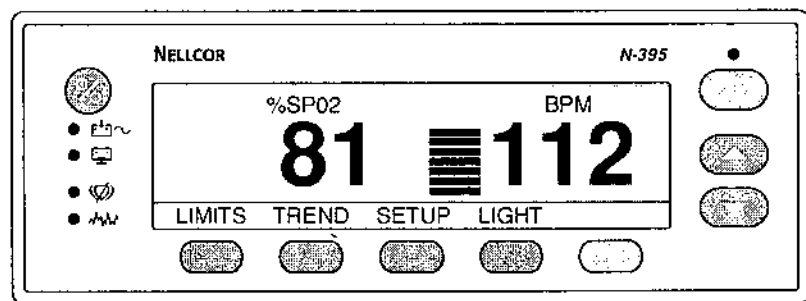

Figure 10: Monitoring Mode Display – Blip (Magnified) View

Adult-Pediatric and Neonatal Settings

WARNING: Each time the monitor is used, check alarm limits to ensure that they are appropriate for the patient being monitored.

Before monitoring, ensure that the N-395 is in the patient setting (adult-pediatric or neonatal) appropriate for the patient being monitored. The default power-on setting from the factory is for adult and pediatric patients. To determine which patient setting the N-395 is in, press the LIMITS softkey. If the monitor is in the adult-pediatric setting, the Adult Limits screen appears in the display.

To change the N-395 from the adult-pediatric setting to the neonatal setting, press the NEO softkey. To change back to adult-pediatric, press the ADULT softkey.

Note: The default power-on operating mode can be changed to the neonatal patient setting by qualified service personnel using the configuration mode described in the N-395 service manual.

When the patient setting (adult-pediatric or neonatal) is changed, alarm limits return to power-on defaults for the respective settings and previous patient data is cleared from the display. In the neonate mode, there are different default settings used. Refer to *Default Settings*, page 58.

Contrast

To adjust the screen contrast, press and hold the CONTRAST Button on the front panel of the monitor. Press the ADJUST UP or ADJUST DOWN Button to increase or decrease the contrast. Continue to press and hold the buttons to adjust the contrast at a faster rate.

Monitoring Mode

In Monitoring Mode - Pleth View (Figure 9), the N-395 displays %SpO₂ readings, pulse rate readings, and a pleth waveform. In the Monitoring Mode - Blip (Magnified) View (Figure 10), the Pulse Amplitude Indicator and a larger %SpO₂ and pulse rate reading are displayed. The pleth waveform is not displayed. Instructions on how to select one of the two views by using the softkeys are given later in this section.

The %SpO₂ is displayed for values between 1% and 100%. Pulse rates are displayed for values from 20 to 250 beats per minute and zero beats per minute. Pulse rates below 20 (except zero) will be displayed as 20, and pulse rates above 250 will be displayed as 250. A pulse rate of zero is used to indicate that the monitor is not monitoring a pulse.

A variable-pitch beep sounds once for each pulse, and the Pulse Amplitude Indicator (in the Blip [magnified] View) visually displays relative pulse strength at the sensor site. The pitch of the beep decreases as %SpO₂ decreases.

Start-Up and Use

Note: Verify that indicators, display information, and audible sounds including alarms are operational, indicating that the monitor is functioning. Each valid button press should generate an appropriate audible or visual action. Observe movement of the Pulse Amplitude Indicator or pleth waveform, and listen for pulse beeps to verify that measurements are being made.

Note: If any action does not seem appropriate, do not use the monitor. Instead, contact Mallinckrodt Technical Services Department or your local Mallinckrodt representative.

In Monitoring Mode, if the acquired pulse is lost, the monitor enters Pulse Search Mode.

Pulse Search

If the acquired pulse is lost during monitoring, the N-395 enters Pulse Search. During Pulse Search, the monitor attempts to detect a pulse from which to take a measurement.

At Initial Power-Up (Sensor Attached to Monitor)

Immediately after POST is completed and the N-395 displays its software version number, the monitor enters Pulse Search Mode and the Pulse Search Indicator lights. If an attached sensor is not connected to a patient, the display reads zeroes and the monitor remains in the Pulse Search Mode for about 5 seconds. After 5 seconds the pulse search is turned off and SpO₂ and Pulse Rate display “--- & ---” (dashes and dashes). If the sensor is connected to the patient, the N-395 enters the Monitoring Mode when a pulse is detected.

At Initial Power-Up (No Sensor Attached to Monitor)

Immediately after POST is completed and the N-395 displays its software version number, the monitor displays dashes. It does not enter the Pulse Search Mode.

After Taking Measurements

If a pulse was previously acquired and then lost, the N-395 enters Pulse Search, and the Pulse Search indicator lights. The last detected readings are displayed while the monitor searches for a valid pulse. When the monitor considers the pulse “lost,” it displays zeroes and a high priority alarm sounds.

When a valid pulse is detected, the N-395 exits the Pulse Search Mode and displays the current readings. The Pulse Search indicator goes out.

Sensor Disconnected

If the sensor cable becomes disconnected from the sensor or the monitor during monitoring, a low priority alarm sounds, values for SpO₂ and pulse rate are replaced with dashes, and SENSOR DISCONNECTED is displayed on the screen.

Sensor Off

If the sensor becomes disconnected from the patient during monitoring, a low priority alarm sounds, values for SpO₂ and pulse rate are replaced with dashes, and SENSOR OFF is displayed on the screen.

Automatic Shutdown

When all of the following conditions are present for 15 minutes, the N-395 will automatically shut down:

- Running on battery power
- No buttons have been pressed
- No pulse has been detected (for example, when no patient is connected to the sensor or the sensor is disconnected)
- No alarms are present (other than low battery or a non-correctable error)

ALARMS

The following paragraphs describe the three levels of audio alarms and discuss the management of the loss-of-pulse alarm.

Description of Alarms

The N-395 has three levels of audible alarms.

1. *High-priority alarm:* Indicated by a fast-rate, high-pitched, pulsing tone. A high-priority alarm sounds after loss-of-pulse is detected.

During a high-priority alarm, the display flashes with the patient parameter that violated the limit.

2. *Medium-priority alarm:* Indicated by a medium-rate, medium-pitched, pulsing tone. A medium-priority alarm sounds when any measured patient parameter moves outside the set alarm limits, and, if enabled, the *SatSeconds* limit has been exceeded.

During a medium-priority alarm, the display flashes with the patient parameter that violated the limit (%SpO₂ or Pulse Rate). If the alarm is a *SatSeconds* alarm, the *SatSeconds* indicator will be full.

3. *Low-priority alarm:* Indicated by a slow, low-pitched, pulsing tone. A low-priority alarm sounds during the following conditions:

- low battery (while operating on battery power)
- when an SpO₂ cable or sensor has been disconnected from the monitor or a patient
- monitor failure

When operating on DC power, during a low battery condition, the Low Battery Indicator illuminates and the alarm tone sounds immediately, even if the alarms are silenced or set to OFF.

SatSeconds Alarm Management

With traditional alarm management, upper and lower alarm limits are set for monitoring oxygen saturation. During monitoring, as soon as an alarm limit is violated by as little as one percentage point, an audible alarm immediately sounds. When the %SpO₂ level fluctuates near an alarm limit, the alarm sounds each time the limit is violated. Such frequent alarms can be distracting.

The N-395 utilizes Nellcor *SatSeconds* alarm management technique. With the *SatSeconds* technique, upper and lower alarm limits are set in the same way as traditional alarm management. The clinician also sets a *SatSeconds* limit that allows monitoring of %SpO₂ below the selected low alarm limit for a period of time before an audible alarm sounds.

The *SatSeconds* limit controls the time that the %SpO₂ level may fall below the alarm limit before an audible alarm sounds.

The method of calculation is as follows:

The number of percentage points that the %SpO₂ falls outside the alarm limit is multiplied by the number of seconds that the %SpO₂ level remains outside that limit. This can be stated as an equation:

$$\text{Points} \times \text{Seconds} = \text{SatSeconds}$$

Where:

Points = SpO₂ percentage points below of the limit

Seconds = number of seconds SpO₂ remains at that point below of the limit

For example, Figure 11 demonstrates the alarm response time assuming a *SatSeconds* limit set at 50, and a lower alarm limit set at 90 percent.

In this example, the %SpO₂ level drops to 88 (2 points) and remains there for a period of 2 seconds (2 points x 2 seconds = 4). The %SpO₂ then drops to 86 for 3 seconds and then to 84 for 6 seconds. The resulting *SatSeconds* are:

Start-Up and Use

%SpO₂	Seconds	SatSeconds
2 x	2 =	4
4 x	3 =	12
6 x	6 =	36
Total SatSeconds =		52

After approximately 10.9 seconds the *SatSeconds* alarm would sound, because 50 *SatSeconds* had been exceeded. See arrow (↑) in Figure 5.

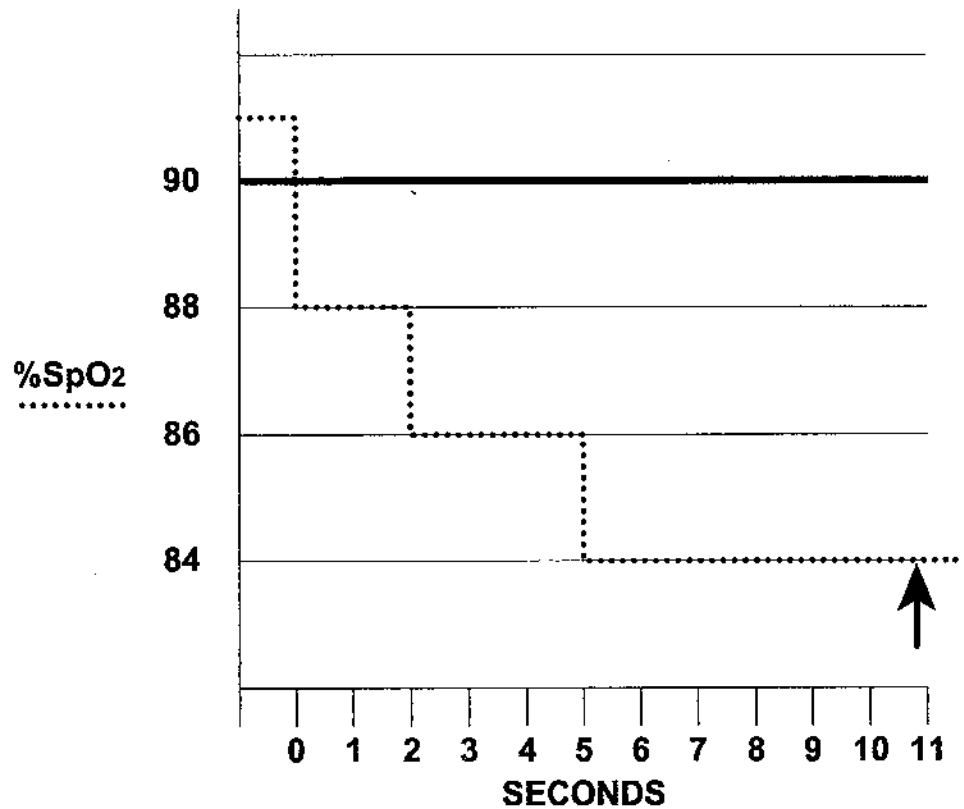

Figure 11: Alarm Response with *SatSeconds*

Saturation levels may fluctuate rather than remaining steady for a period of several seconds. Often, %SpO₂ levels may fluctuate above and below the alarm limit, re-entering the non-alarm range several times.

During such fluctuation, the N-395 integrates the number of %SpO₂ points, both positive and negative, until either the *SatSeconds* limit (*SatSeconds* setting) is reached, or the %SpO₂ level returns within a normal range and remains there.

***SatSeconds* "Safety Net"**

The *SatSeconds* "Safety Net" is for patients with saturation having frequent excursions below the limit, but not staying below the limit long enough for the *SatSeconds* setting to be reached. When 3 or more limit violations occur in 60 seconds an alarm will sound even if the *SatSeconds* setting has not been reached.

Determining the *SatSeconds*

The *SatSeconds* setting may be set at 10, 25, 50, or 100 *SatSeconds*, or it may be set to OFF. The factory default setting is "OFF". The decision to utilize the *SatSeconds* feature and at what limit, or not to use it at all, must be made based on the medical assessment of the patient's clinical signs and symptoms.

To set the *SatSeconds* limit:

1. Press the LIMITS softkey.
2. Press the SELECT softkey to move to %SpO₂ SECS.
3. When the %SpO₂ SECS field is highlighted, use the ADJUST UP or ADJUST DOWN button to select the desired limit. Choices are: 10, 25, 50, or 100 or OFF.
4. After selecting the *SatSeconds* limit; press the EXIT softkey to return to the main display.

SatSeconds Display

When the N-395 *SatSeconds* technology detects an SpO₂ value outside the alarm limit, the *SatSeconds* indicator begins to “fill” clockwise. When the SpO₂ value is within the set limits, the *SatSeconds* indicator will empty counter-clockwise. As seconds pass and are compared against the alarm-limit and the *SatSeconds* setting, the graph fills or empties proportionately. The *SatSeconds* circular graph is located on the right side of the display, adjacent to the SpO₂ reading in the pleth view and at the far left of the display in the blip view.

When the graph is completely filled, indicating that the selected *SatSeconds* limit has been reached, an audible alarm sounds and the displayed %SpO₂ value flashes. As with traditional alarm management, the audible alarm may be silenced by pressing the ALARM SILENCE button.

ADJUSTABLE SETTINGS

The following adjustments can be made using the Adjust Up/Down and ALARM SILENCE Buttons.

- Pulse beep volume
- Alarm volume
- Alarm silence duration
- Disabling audible alarms

Pulse Beep Volume

To adjust the pulse beep volume during normal monitoring, press and hold the ADJUST UP or ADJUST DOWN Button to change the setting. Pressing and holding the ADJUST DOWN Button will cause the volume to decrease until it is no longer heard.

Alarm Volume

To *view* the current volume of the audible alarm, press and hold the ALARM SILENCE Button for more than 3 seconds. The current volume level is indicated in the Pulse Rate Display as a value from 1 (lowest) to 10 (highest). A tone at the displayed level sounds.

To *adjust* the volume, press and hold the ALARM SILENCE Button until VOL is displayed. Continue pressing the ALARM SILENCE Button and press the ADJUST UP or ADJUST DOWN Button to change the setting. The volume cannot be set to zero.

Alarm Silence Duration

Alarms can be silenced for a preset period called the *audible alarm silence duration*. To view the current setting, press and hold the ALARM SILENCE Button for less than 3 seconds. To adjust the setting, press and hold the ALARM SILENCE Button (for less than 3 seconds) and use the ADJUST UP or ADJUST DOWN Buttons to increase or decrease the value. Possible values are 30, 60, 90, or 120 seconds, or OFF. (The OFF selection is discussed later in this section.)

The audible alarm silence duration begins when the ALARM SILENCE Button is pressed.

Subsequently, if any alarm condition (other than a low battery alarm) occurs while the alarm is silenced, the alarm will not sound until the alarm silence duration period expires. Operating the monitor on battery power during a low battery alarm condition will cause a low battery alarm to sound, even if the duration time has not elapsed.

If the ALARM SILENCE Button is pressed during the alarm silence duration, the alarm silence duration is ended and the audible alarms are re-enabled.

Visual indications of an alarm condition cannot be turned off. For example, if the %SpO₂ SatSeconds upper alarm limit is exceeded, the alarm can be silenced for the alarm silence duration, but the %SpO₂ value will continue to flash.

Start-Up and Use

If the alarm condition is still present when the alarm silence duration has elapsed, the alarm will sound.

WARNING: Do not silence an audible alarm or decrease its volume if patient safety could be compromised.

Disabling Audible Alarms

Setting the alarm silence duration to OFF means that the monitor will produce no audible alarms.

To set the alarm silence duration to OFF, press and hold the ALARM SILENCE Button for less than 3 seconds and use the ADJUST UP Button to increase the current setting until “OFF” is displayed. The Alarm Silence Indicator flashes, indicating that audible alarms have been disabled. To re-enable audible alarms, the duration must be set to something other than OFF.

Visual indications of an alarm condition are not affected by disabling the audible alarms.

The ability to set the alarm silence duration to OFF can be enabled or disabled by qualified service personnel as described in the service manual.

The factory default is that the capability of setting the alarm silence duration to OFF is enabled.

Alarm Silence Reminder

The factory default is that the reminder is enabled. Service personnel must enable or disable this function as required by each institution. Refer to the N-395 service manual for the procedure.

MENU

Menu Structure

The four softkeys on the front panel are used to view or adjust the following N-395 settings or functions:

- %SpO₂ and pulse rate alarm limits
- Pleth or Blip view
- Time and date settings
- Data port baud rate settings
- Trend data viewed (%SpO₂, pulse, or both)
- “Zoom” factor of trend data
- Graph of trend data (histogram)
- Delete all trend data
- Print trends
- *SatSeconds* limits
- Language displayed on screen or data port
- Nurse call settings
- Analog output calibration voltage settings
- Display backlight on/off

Menu items are selected by pressing and releasing the corresponding softkey directly below the item. Refer to Table 2: Limits Menu to access menu items.

Note: If, after accessing a submenu, no buttons are pressed for 10 seconds, the display will time out and return to the main menu. Exceptions to this are the clock and trend menus, which will time out in 5 minutes and the analog port calibration menu, which times out in 2 minutes.

Start-Up and Use

A description of each menu item is included in the following paragraphs.

LIMITS

WARNING: Each time the monitor is used, check alarm limits to ensure that they are appropriate for the patient being monitored.

Overview

When the N-395 is first turned on, alarm limits are set to their power-on default values. Qualified service personnel, using the instructions described in the N-395 service manual, may change power-on default alarm limits.

Alarm limits may be changed from their power-on default values if necessary, as described below. Limit changes made will remain in effect until changed again or until the N-395 is turned off.

Viewing Current Alarm Limits

To view the current alarm limit values from the main menu, press the LIMITS softkey. The current upper and lower alarm limits for %SpO₂ and pulse rate are displayed. The current *SatSeconds* alarm limit is also shown.

Changing Alarm Limits

Use the SELECT softkey to select the parameter that is to be changed. Use the ADJUST UP/DOWN Buttons to change the settings. The setting takes effect immediately and remains in effect when the alarm setting menu is exited.

Table 2: Limits Menu

LIMITS	
_____	SELECT
_____	NEO
_____	ADULT
_____	EXIT

Table 3: Trend Menu

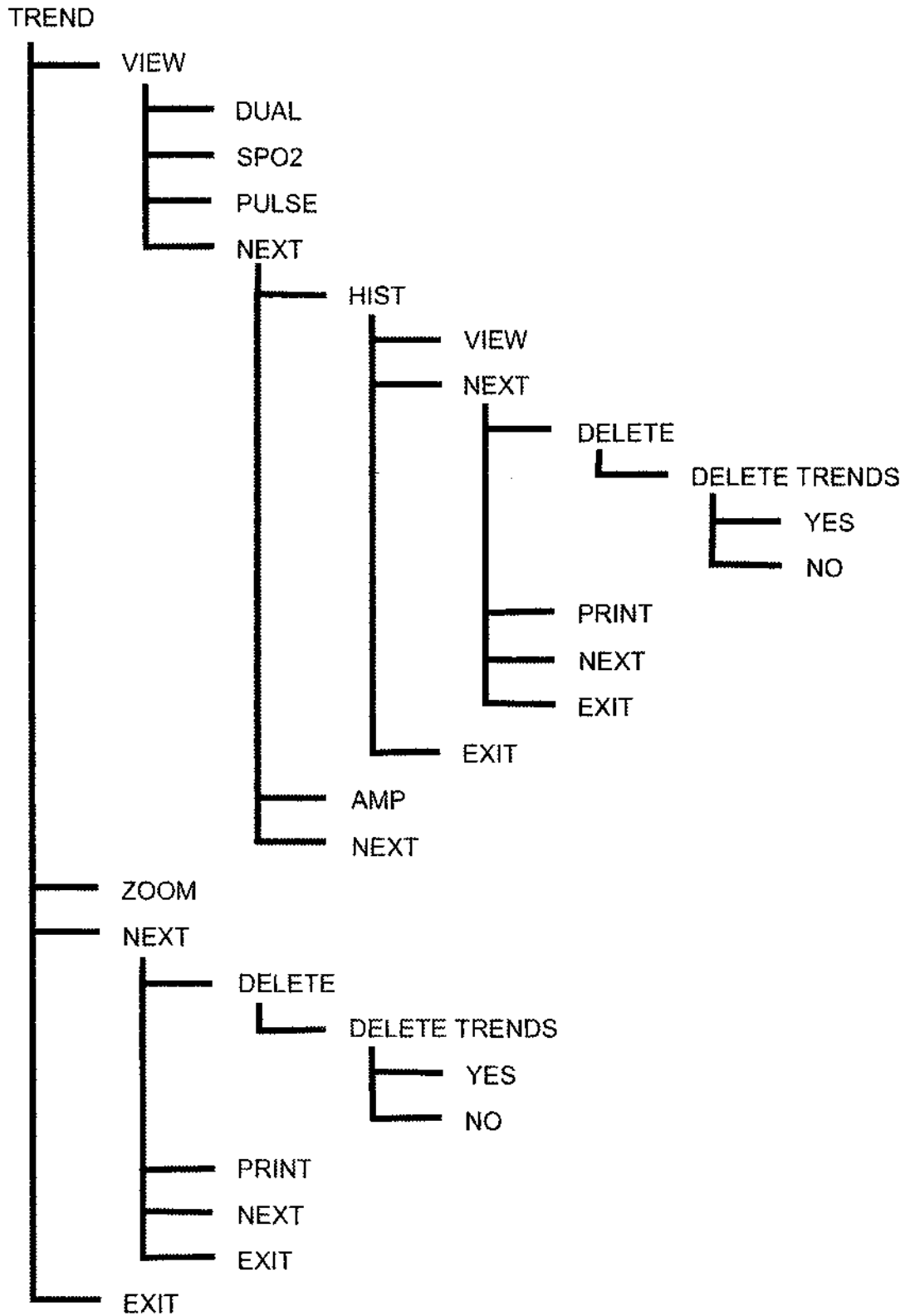
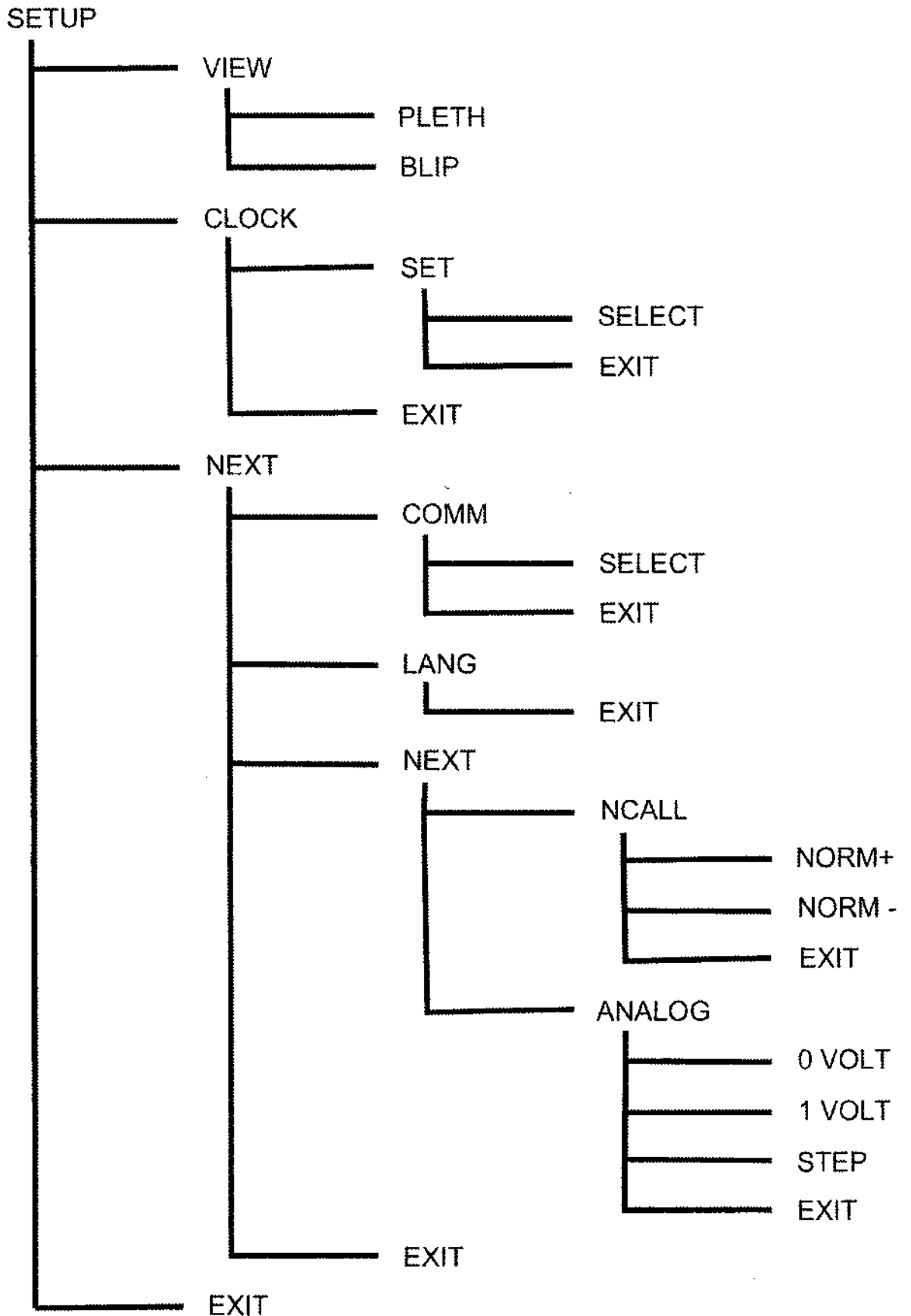

Table 4: Setup Menu



Alarm Limits Changed Indicator

If alarm limits are changed from the N-395's power-on defaults, a decimal point appears after the displayed value and in the %SpO₂ and Pulse Rate Display as illustrated in Figure 12. The decimal point remains on the display until the N-395 is turned off or the limit is returned to its default value.

ADULT LIMITS			%SP02	96.
	%SPO2	BPM		
UPPER	100	170	BPM	79
LOWER	80.	40		
SECS	OFF			
SELECT	NEO	ADULT	EXIT	

Figure 12: Alarm Limits Selection

TREND

The N-395 can graphically display trends for SpO₂, pulse rate, or both. Trend data is stored at 4-second intervals. When the TREND softkey is pressed, "READING TRENDS . . ." is displayed at the bottom of the screen, indicating that the monitor is collecting the trend data.

The monitor stores up to 48 hours of trend data. The amount of trend data displayed on the screen is determined using the ZOOM softkey. Settings available are 40 seconds, 15 or 30 minutes, and 1, 2, 4, 8, 12, 24, 36, or 48 hours. All data are displayed in a graph format except the 40-second setting, which is shown in tabular format.

When the trends are displayed, the most recent readings are on the right side of the graph. The graph indicates the highest and lowest parameter values during the period of time represented by the width of the cursor (vertical dotted line).

The highest and lowest values of the parameter at the cursor are indicated on the left side of the screen ("95" and "98" in Figure 13). These values are *not* the current patient readings but represent the highest/lowest trend values at the cursor.

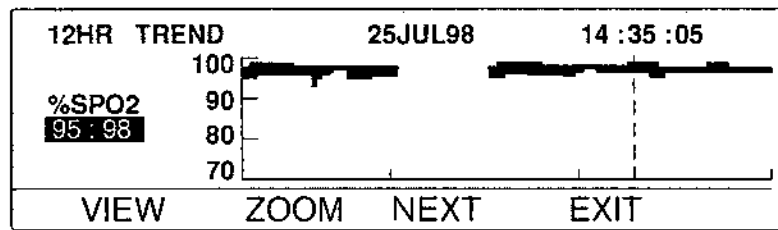

Figure 13: SpO₂ Trend

Periods of time when no measurements were acquired are indicated by blank spaces in the graph as shown in Figure 13.

The number of trend hours or minutes currently displayed on the screen is indicated in the upper left corner. The date and time indicate the location of the cursor on the top middle and right of the screen.

The cursor is moved right or left by using the ADJUST UP/DOWN Buttons. Each press of the button causes the cursor to move a certain period of time depending on the trend scale, as indicated in Table 5.

Table 5: Trend Scale

Trend Scale	Amount of Time Represented by One Press of the ADJUST UP/DOWN Button
40 seconds	4 seconds
15 minutes	5 seconds
30 minutes	10 seconds
1 hour	20 seconds
2 hours	40 seconds
4 hours	1 minute, 20 seconds
8 hours	2 minutes, 40 seconds
12 hours	4 minutes
24 hours	8 minutes
36 hours	12 minutes
48 hours	16 minutes

Start-Up and Use

Scrolling past the limits of the right or left edges of the screen causes the viewing area to shift, relocating the cursor to the middle of the screen if enough trend data is available.

For example, suppose the time represented by the right-hand edge of the screen in Figure 13 is 14:54:05. Scrolling one time period to the right (4 minutes) results in the cursor relocating to the center of the screen at the time period 14:58:05, with 6 hours of data on both sides of the cursor. If no data were available to the right of the screen, an invalid tone would sound. If only 3 hours of data was to the right of the screen, the cursor would relocate to approximately 3/4 of the way to the right of the screen, at the time period 14:58:05.

Note: The screen will return to the monitoring mode if an alarm sounds, the ALARM SILENCE Button is pressed or a trend or histogram has been displayed for 5 minutes with no button presses.

View

Pressing the VIEW softkey allows selection of the following trend displays: DUAL, SPO2, PULSE, HIST, or AMP. To select HIST or AMP press VIEW, then NEXT.

Dual Trend Display

The dual trend display provides trend information on the %SpO₂ and pulse rate. See Figure 14.

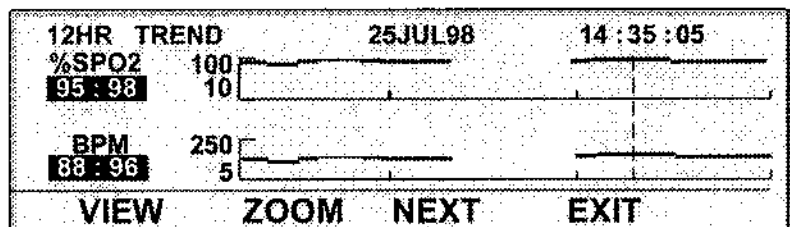

Figure 14: Dual Trend Display

SpO₂ Trend Display

The SpO₂ trend display provides information on the %SpO₂ trend. See Figure 15.

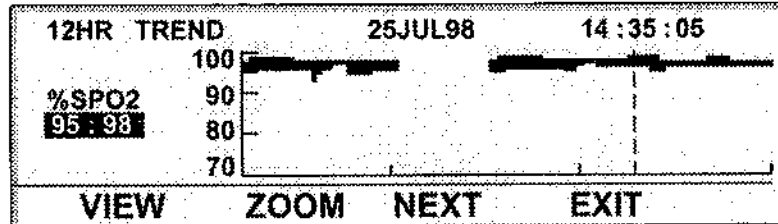

Figure 15: SpO₂ Trend Display

Pulse Rate Trend Display

The pulse rate trend display provides information on the pulse rate trend. See Figure 16.

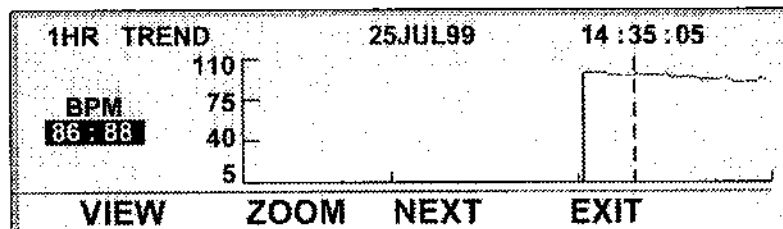

Figure 16: Pulse Rate Trend Display

Histogram

The histogram view is illustrated in Figure 17. The histogram graphically illustrates the percentage of time a given range of values has been measured. The period of time covered is given in the upper left corner of the display. Only points with data are included in the histogram.

For example, in Figure 17, the histogram is for the last 12 hours. During those 12 hours, 68% of the %SpO₂ measurements were from 96 to 100, 7% of the measurements were from 91 to 95, and 25% of the measurements were from 0 to 80.

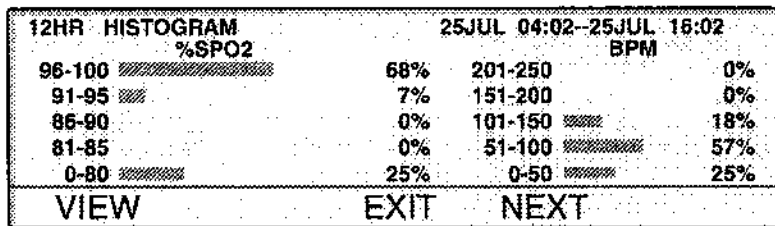

Figure 17: Histogram

AMP (Amplitude) Trend Display

The AMP trend display provides trend information on the pulse amplitude. See Figure 18.

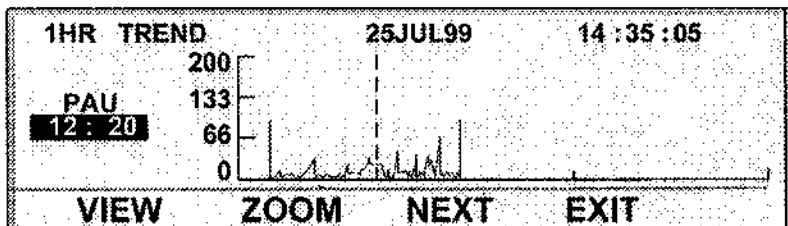

Figure 18: AMP Trend Display

Zoom

Pressing the ZOOM softkey changes the period of time displayed on a trend graph. Selectable times displayed graphically in the upper left corner are 48, 36, 24, 12, 8, 4, 2, or 1 hours, and 30 or 15 minutes. The location of the cursor, as indicated by the time in the upper right-hand corner of the screen, remains the same.

A table is used to display 40-second trends.

The ZOOM softkey is not displayed for the histogram trend view.

40-Second Trends Table

The 40-second trends table is available by continuing to press the ZOOM softkey. As indicated in Figure 19, the time indicated on trend graphs by the cursor is displayed in the upper right-hand corner of the screen and is highlighted in the table. Press the DOWN ARROW button to highlight the time of the trends readings. The readings are in 4-second increments and go

back in time as the DOWN ARROW button is pressed and forward in time as the UP ARROW button is pressed.

40SEC TREND			28JUL98	21:31:48		
TIME	%SPO2	BPM	TIME	%SPO2	BPM	
21:31:28	96	78	21:31:48	97	78	
21:31:24	97	79	21:31:44	97	79	
21:31:20	97	78	21:31:40	97	80	
21:31:16	97	78	21:31:36	96	78	
21:31:12	97	78	21:31:32	96	78	
VIEW	ZOOM	NEXT	EXIT			

Figure 19: 40-Second Trends

When the oldest reading on the screen is highlighted and the DOWN ARROW button is pressed again, the screen shifts to display an older column of readings. Similarly, if the newest reading on the screen is highlighted and the UP ARROW button is pressed, the screen shifts to display a newer column of readings.

Next

The NEXT softkey provides access to the DELETE and PRINT softkeys.

Delete

Pressing the DELETE softkey presents two options: YES or NO. YES deletes all trend information from the N-395 memory and the display. NO returns the N-395 to the previous menu.

Print

Note: The protocol setting must be set to ASCII MODE or GRAPH MODE to transmit text or graphical data. Check this setting using the COMM softkey as indicated in the following paragraphs.

ASCII MODE: Pressing the PRINT softkey begins the transmission of data via the data port to a connected PC or serial printer. The output is tabular and all 48 hours of data in memory will be output.

Start-Up and Use

GRAPH MODE: The graph mode disables all printouts except for trend printouts. Pressing the PRINT softkey from the trend menu will print a graphical printout of the displayed graphical trend data. The amount of data printed is the same as the trend being displayed. Contact Mallinckrodt's Technical Services Department for a list of compatible printers.

Refer to *Data Port Protocol* of this manual for more information concerning the data port.

SETUP

The SETUP softkey allows selection or viewing of the following settings:

- view displayed on the screen (PLETH or BLIP)
- time and date
- data port baud rate and protocol
- language displayed on the screen
- data port nurse call normally high or normally low setting
- data port analog calibration voltage.

Press the SETUP softkey once to display VIEW and CLOCK. Then press NEXT to display COMM and LANG. Press NEXT again to display NCALL and ANALOG.

VIEW

The VIEW softkey allows selection of the screen to be displayed, PLETH or BLIP (magnified). The pleth view displays the pleth waveform. The BLIP view displays the Pulse Amplitude Indicator and larger numerical values for easier viewing.

CLOCK

The CLOCK softkey provides a means to set the time and date.

Press the SET softkey to access the SELECT softkey. Use the SELECT softkey to select the item to be changed. Use the ADJUST UP/DOWN Buttons to adjust the setting. The date is expressed as DD-MMM-YY. For example, November 29, 1998, would be expressed as 29 - NOV - 98.

Note: The N-395 will time out in 5 minutes when the SET and EXIT softkeys are displayed. However, it will time out in 10 seconds after the SET button is pressed if there are no further button presses.

Press the EXIT button to accept the new settings. Press EXIT again to return to the previous menu.

COMM

Press the NEXT softkey to access the COMM softkey. The COMM softkey provides selection of the baud rate and the protocol of the data port.

After pressing the COMM softkey, use the ADJUST UP/DOWN Buttons to select a baud rate of 2400, 9600, or 19200. Press Exit to return to the SETUP submenu.

Press the SELECT softkey to highlight the protocol setting. Use the ADJUST UP/DOWN Buttons to select the desired setting. ASCII is used during normal operation and for serial printers. GRAPH is used for graphical trend printouts when connected to a serial printer. Select OXINET when connecting to an *Oxinet*[®] II central station network or Score software. The Bedside Monitor Interface selections are (contained in N-395 software versions 1.7 and higher) AGILENT (for Agilent HP monitors), SPACELBS (for SpaceLab monitors), MARQ (for Marquette monitors), and DATEX (for Datex-Ohmeda AS/3 monitors). Do not use the CLINICAL setting unless instructed to do so by Mallinckrodt's Technical Services personnel. Press Exit to return to the SETUP submenu.

Bedside Monitor Interface

The bedside monitor interface (contained in N-395 software versions 1.7 and higher) allows the N-395 monitor to communicate real-time monitoring information to a "host" bedside monitor. The purpose of bedside monitor interface is to allow integrate *Oxismart*[®] XL oximetry technology into the host system for remote monitoring, trending, data storage, and other features offered by the "host" system.

Start-Up and Use

Agilent (HP) Communications

The N-395 sends SpO₂, pulse rate, and alarm status data to the Agilent monitor.

The Agilent monitor requires an Agilent *VueLink*[™] Aux Plus B interface module to interface with the N-395 pulse oximeter.

The RS-232 hardwire interface cable has a DB-15 connector for the N-395 and the applicable connector for the Agilent monitor. Nellcor cable part number 902256 is recommended for this interface.

Note: Spare parts for the N-395 are listed on the Internet, confirm the cable part number before ordering a cable.

The Internet address is:

http://mallinckrodt.com/respiratory/resp/Serv_Supp/Partweb/main/PartAcceMenu.html.

A blank screen on the Agilent monitor will indicate corrupt data. The Agilent monitor will detect corrupt data in less than 100 milliseconds.

When the N-395 is in the Agilent mode of operation the interface baud rate must be set to 19,200 bits per second. Press the SETUP softkey, then the NEXT softkey, and then the COMM softkey to select BAUD. Use the ADJUST UP or ADJUST DOWN buttons to select the correct baud rate.

WARNING: Do not silence the N-395 audible alarm or decrease its volume if patient safety could be compromised.

The Agilent monitor only displays visual alarm indications. The N-395 monitor must be able to sound an audible alarm in order to maintain patient safety.

SpaceLabs Communications

The N-395 sends SpO₂, pulse rate, and alarm status data to the SpaceLabs monitor.

Figure 20 illustrates the connections between the N-395 and the SpaceLabs Monitor.

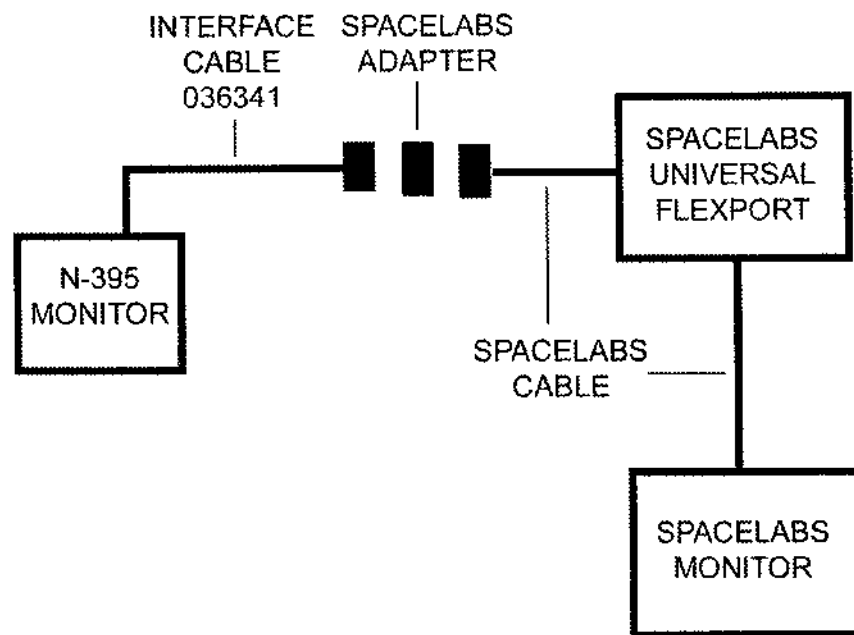

Figure 20: SpaceLabs Connection

Caution: The SpaceLabs monitor must be turned on before the N-395 monitor is turned on.

The SpaceLabs monitor requires a Universal *FlexPort*™ interface module to interface with the N-395 pulse oximeter.

The RS-232 hardwire interface cable has a DB-15 connector for the N-395 and the applicable connector for the SpaceLabs *FlexPort* interface module cable. Nellcor cable part number 036341 is recommended for this interface.

Note: Spare parts for the N-395 are listed on the Internet, confirm the cable part number before ordering a cable. The Internet address is:
http://mallinckrodt.com/respiratory/resp/Serv_Supp/Partweb/main/PartAcceMenu.html.

Corrupt data will be indicated by a Communications Error displayed on the SpaceLabs monitor. The SpaceLabs monitor will detect corrupt data in less than 11 seconds.

When the N-395 is in the SpaceLabs mode of operation the interface baud rate must be set to 9,600 bits per second. Pressing the SETUP softkey, then the NEXT softkey, and then the COMM softkey to select BAUD. Use the ADJUST UP or ADJUST DOWN buttons to select the correct baud rate.

Start-Up and Use

WARNING: Do not silence the N-395 audible alarm or decrease its volume if patient safety could be compromised.

The SpaceLabs monitor provides both audible and visual alarm indications. Silencing the N-395 alarm will also silence the SpaceLabs monitor alarms. The monitors must be able to sound an audible alarm in order to maintain patient safety.

Marquette Communications

The N-395 sends SpO₂, pulse rate, and alarm status data to the Marquette monitor.

The Marquette monitor requires an *Octanet*[™] interface module to interface with the N-395 pulse oximeter. The interface module comes with an interface cable, GE Marquette part number 417961-033, that connects to the Nellcor interface cable.

The RS-232 hardwire interface cable has a DB-15 connector for the N-395 and the applicable connector for the Marquette *Octanet*[™] interface module cable. Nellcor cable part number 902254 is recommended for this interface.

Note: Spare parts for the N-395 are listed on the Internet, confirm the cable part number before ordering a cable. The Internet address is:
http://mallinckrodt.com/respiratory/resp/Serv_Supp/Apartweb/main/PartAcceMenu.html.

Corrupt data will be indicated by a Communications Error displayed on the Marquette monitor. The Marquette monitor will detect corrupt data in less than 7 seconds.

When the N-395 is in the Marquette mode of operation the interface baud rate must be set to 9,600 bits per second. Pressing the SETUP softkey, then the NEXT softkey, and then the COMM softkey to select BAUD. Use the ADJUST UP or ADJUST DOWN buttons to select the correct baud rate.

The GE Marquette monitor only sounds audible alarms. Silencing the N-395 audible alarm has no effect on the GE Marquette monitor sounding an alarm.

Datex-Ohmeda Communications

The Datex-Ohmeda monitor AS/3 must be configured for communications with the Nellcor N-200 monitor in order to communicate with the N-395 monitor. Refer to the AS/3 operator's manual for instructions on configuring the AS/3 monitor.

The N-395 sends SpO₂, pulse rate, and alarm status data to the Datex AS/3 monitor.

The RS-232 hardwire interface cable has a DB-15 connector for the N-395 and the applicable connector for the Datex monitor. Nellcor cable part number 902255 is recommended for this interface.

Note: Spare parts for the N-395 are listed on the Internet, confirm the cable part number before ordering a cable. The Internet address is:
http://mallinckrodt.com/respiratory/resp/Serv_Supp/Partweb/main/PartAcceMenu.html.

Corrupt data will be indicated by a Communications Error displayed on the Datex monitor. The Datex monitor will detect corrupt data in less than 11 seconds.

When the N-395 is in the Datex mode of operation the interface baud rate must be set to 2,400 bits per second. Pressing the SETUP softkey, then the NEXT softkey, and then the COMM softkey to select BAUD. Use the ADJUST UP or ADJUST DOWN buttons to select the correct baud rate.

WARNING: Do not silence the N-395 audible alarm or decrease its volume if patient safety could be compromised.

The Datex-Ohmeda monitor does not indicate audible or visual alarms. The N-395 monitor must be able to sound an audible alarm in order to maintain patient safety.

LANG

The LANG softkey provides selection of the language displayed on the screen.

Start-Up and Use

Press the NEXT softkey to access the LANG softkey. After pressing the LANG softkey, use the ADJUST UP/DOWN Buttons to select English, French, German, Italian, Spanish, Dutch, or Portuguese.

If the language is changed and EXIT is pressed (or a 10-second timeout occurs), the monitor begins displaying data in the selected language.

NCALL

The NCALL softkey provides the capability of setting the alarm voltage at a normally high (NORM +) or normally low (NORM -). Refer to the “Nurse Call” heading of *Data Port Protocol* for a more thorough explanation of these settings. The nurse call feature is also discussed later in this section.

ANALOG

The ANALOG softkey provides the capability to produce variable calibrating voltages to calibrate instruments such as a chart recorder. Refer to the “Analog Outputs” heading of *Data Port Protocol* for a more thorough explanation of these settings.

LIGHT

The LIGHT softkey turns the backlight on or off. When the backlight is off, pressing any softkey turns the backlight on. Also, the CONTRAST and ALARM SILENCE keys will turn the backlight on. Any alarm will turn the backlight on. Turning the backlight off conserves battery power.

Default Settings

The N-395 is shipped with factory default settings (Table 6 and Table 7). Authorized technical personnel using the procedures described in the N-395 service manual can change default settings.

Note: Factory default settings are constants that cannot be changed without re-compiling software.

Table 6: Factory Default Settings (Adult)

Monitoring Mode	Adult
%SpO ₂ Lower Alarm Limit:	85%
%SpO ₂ Upper Alarm Limit:	100%
Alarm Silence Duration OFF Setting:	Enabled
Alarm Silence Duration:	60 seconds
Alarm Silence Reminder:	Enabled
Alarm Volume:	75 dB(A) peak at 1 meter (volume setting of 5)
Data Port Baud Rate:	9600
Data Port Protocol:	ASCII
Display Contrast:	Midrange
Display Format:	Pleth
Language:	English
Nurse Call Polarity:	Normally Low
Pulse Beep Volume:	72 dB(A) at 1 meter (volume setting of 4)
Pulse Rate Lower Alarm Limit:	40 beats per minute
Pulse Rate Upper Alarm Limit:	170 beats per minute
<i>SatSeconds</i>	Off
Trend Display:	%SpO ₂

Table 7: Factory Default Settings (Neonate)

Monitoring Mode	Neonate
Note: There are different default settings for the neonate mode.	
%SpO ₂ Lower Alarm Limit:	80%
%SpO ₂ Upper Alarm Limit:	95%
Pulse Rate Lower Alarm Limit:	90 beats per minute
Pulse Rate Upper Alarm Limit:	190 beats per minute
<i>SatSeconds</i> :	Off

Nurse Call Feature

WARNING: The nurse call feature should not be used as the primary source of alarm notification. The audible and visual alarms of the monitor, used in conjunction with clinical signs and symptoms, are the primary sources for notifying medical personnel that an alarm condition exists.

The nurse call feature of the N-395 works in conjunction with the nurse call system of the institution when the monitor sounds an audible alarm. It is accessed through the data port (pins 7, 8, 10, 11, or 15, as indicated in Table 10).

WARNING: The nurse call feature is not functional whenever the monitor alarms are silenced.

The nurse call feature is available when the N-395 is operated on AC power or its internal battery, and the monitor has been electronically connected to the hospital's nurse call system. Qualified service personnel may refer to the N-395 service manual for complete connection instructions.

Prior to using the monitor in a clinical setting, test the nurse call feature by creating an alarm condition, then verifying that the hospital's nurse call system is activated.

BATTERY OPERATION

The N-395 has an internal battery that may be used to power the monitor during transport or when AC power is not available. A new, fully charged battery will provide at least 2 hours of monitoring time under the following conditions: no audible alarms sound, and no analog or serial output devices are attached.

Note: Whenever the monitor is connected to AC power, the battery is being charged. Therefore, it is recommended that the monitor remain connected to AC power when not in use. This will make available a fully charged battery for use at any time.

The monitor cannot operate with a fully discharged battery. Before attempting to turn on an N-395 whose battery charge has been depleted, first plug the monitor into an AC outlet to allow the battery to charge for a few minutes. The monitor may then be powered on.

To charge a dead battery, connect the monitor to AC power. A full charge takes 14 hours while the monitor is turned off.

When all of the following conditions are present for 15 minutes, the N-395 will automatically shut down:

- Monitor is running on battery power
- No buttons have been pressed
- No pulse has been detected (for example, when no patient is connected to the sensor or the sensor is disconnected)
- No alarms are present (other than low battery or a non-correctable error)

Low Battery Indicator

The Low Battery Indicator lights and a low priority alarm begins to sound when approximately 15 minutes of monitoring time is available on the existing battery charge. This alarm cannot be silenced while operating on battery power.

Start-Up and Use

Note: If the AC voltage selector switch on the rear panel does not match the AC voltage source, the monitor may run on battery power, even though it is plugged in, which will eventually result in a low priority alarm and a lighted low battery indicator. Ensure that the switch setting matches the AC voltage.

If the monitor is not connected to AC power within approximately 15 minutes, it will shut down.

Note: As the battery is used and recharged over a period of time, the amount of time between the onset of the low battery alarm and the instrument shut-off may become shorter.

If the backlight is turned off during a low battery condition, it cannot be turned back on.

It is recommended that qualified service personnel replace the internal battery every 24 months.

Caution: If the N-395 is to be stored for a period of 3 months or longer, notify service personnel to remove the battery from the monitor prior to storage. Recharge the battery when it has not been charged for 2 or more months.

DISPOSAL OF DEVICE COMPONENTS

Caution: Follow local governing ordinances and recycling instructions regarding disposal or recycling of device components, including batteries.

PERFORMANCE CONSIDERATIONS

Impact of Patient Conditions on Monitor Readings

Certain patient conditions can affect the measurements of the N-395 and cause the loss of the pulse signal.

WARNING: Pulse oximetry readings and pulse signals can be affected by certain ambient environmental conditions, sensor application errors, and certain patient conditions.

Inaccurate measurements can be caused by:

- prolonged patient movement
- venous pulsations
- intravascular dyes, such as indocyanine green or methylene blue
- significant levels of dysfunctional hemoglobins
- defibrillation

Ambient environmental conditions and sensor application errors, which can affect pulse oximetry readings, are discussed in the *Sensors and Accessories* section of this manual and in the sensor directions for use.

The effects of electromagnetic interference on oximetry readings are discussed in the *Troubleshooting and Maintenance* section of this manual.

TROUBLESHOOTING AND MAINTENANCE

Troubleshooting
EMI (Electromagnetic Interference)
Obtaining Technical Assistance
Returning the N-395
Maintenance

TROUBLESHOOTING

WARNING: If you are uncertain about the accuracy of any measurement, check the patient's vital signs by alternate means; then make sure the monitor is functioning correctly.

WARNING: The cover should be removed only by qualified service personnel. There are no user-serviceable parts inside.

Error Codes

When the N-395 detects an error condition, it may display the letters "EEE" followed by an error code.

When an error code (other than the ones listed in Table 8) is displayed, turn the instrument off and back on again. If the error code reappears, record it and notify service personnel.

Error messages will be displayed along with the error codes listed in Table 8. If the error codes are encountered, perform the prescribed action as indicated in the table.

Table 8: Error Codes and Messages

Error Code	Error Message	Action
4	LOW BATTERY	The battery is discharged to a critically low level. Check to ensure that the voltage selector switch on the rear panel is set to the proper voltage. Turn the monitor off and let it charge for approximately 10 minutes and then reattempt to turn the unit on. If the error code is still present, turn the unit off and let it continue to charge. If the monitor has been charged for 30 minutes and the error code is still present, notify service personnel.
80	DEFAULTS LOST	The current power-on default settings have been lost and returned to factory defaults. Qualified service personnel can use the service manual to restore the desired power-on default settings.
81	SETTINGS LOST	The current settings (for example, alarm limits, alarm and pulse beep volumes, alarm silence duration) have been lost and returned to power-on defaults. Turn the monitor off and back on again. If it is necessary to have settings different from the power-on default settings, turn the monitor off and back on again, and reenter the desired settings.
82	CLOCK SETTING LOST	The date and time settings have been lost. Re-enter the date and time.

Other Messages

In addition to the messages listed in Table 8, the following messages may be encountered:

SENSOR DISCONNECTED - The sensor has disconnected from the cable, the cable has disconnected from the monitor, or the sensor/cable wiring is defective. Press the **ALARM SILENCE** Button to silence the alarm. Check the connections. If this does not correct the problem, replace the sensor and/or cable.

SENSOR OFF - The sensor has become disconnected from the patient. Press the **ALARM SILENCE** Button to silence the alarm. Check the sensor to patient connection. If this does not correct the problem, replace the sensor.

DISALLOWED ON BATTERY - An attempt to print or download data port information while operating on battery power has been made. Connect to AC power and retry.

DISALLOWED ON LOW BATTERY - An attempt to turn on the backlight has been made while in a low battery condition. If the backlight is turned off during a low battery condition, it cannot be turned back on.

READING TRENDS - The monitor is gathering trend information for display.

INVALID SILENCE DURATION - An attempt has been made to set the alarm silence duration power-on default to "OFF." The power-on default cannot be set to "OFF."

INVALID SpO₂ LIMIT - An attempt has been made to set either the upper or lower alarm limit power-on default below 80. The power-on default cannot be set below 80.

Suggested Corrective Actions

If you experience a problem while using the N-395 and are unable to correct it, contact qualified service personnel or your local Mallinckrodt representative. The N-395 service manual, which is for use by qualified service personnel, provides additional troubleshooting information.

Following is a list of possible errors and suggestions for correcting them.

1. There is no response to the **POWER ON/OFF** Button.
 - If operating on AC power, ensure that the supply voltage selector switch is set to the proper voltage.
 - If operating on AC power, the fuse may be blown. Notify service personnel to check and, if necessary, replace the fuse.

Troubleshooting and Maintenance

- If operating on battery power, the battery may be missing or discharged. If the battery is discharged, notify service personnel to charge or replace the battery.
2. One or more display elements or indicators do not light during the power-on self-test.
 - Do *not* use the N-395; contact qualified service personnel or your local Mallinckrodt representative.
3. The monitor is operating on battery power, even though it is connected to AC.
 - Ensure that the supply voltage selector switch is set to the proper voltage.
 - Make sure that the power cord is properly connected to the N-395.
 - Check to see if power is available to other equipment on the same AC circuit.
4. The Pulse Search Indicator is lit for more than 10 seconds (before any measurements are taken).
 - Check the sensor directions for use to determine if an appropriate sensor is being used and if it is applied properly. Check sensor and sensor cable connections. Test the sensor on someone else. Try another sensor or sensor cable.
 - Perfusion may be too low for the N-395 to track the pulse. Check the patient. Test the instrument on someone else. Change the sensor site. Try another type of sensor.
 - Excessive patient motion may be preventing the N-395 from tracking the pulse. Keep the patient still, if possible. Verify that the sensor is securely applied, and replace it if necessary. Change the sensor site. Use a type of sensor that tolerates more patient movement; for example, an adhesive sensor.

- The sensor may be too tight, there may be excessive ambient light, or the sensor may be on an extremity with a blood pressure cuff, arterial catheter, or intravascular line. Reposition sensor, as necessary.
 - Excessive environmental motion or electromagnetic interference may be preventing the N-395 from tracking the pulse. Remove the source of interference or try to stabilize the environment, or do both.
5. The Pulse Search Indicator lights after successful measurements have been made.
- Check the patient.
 - Perfusion may be too low for the N-395 to track the pulse. Test the instrument on someone else. Change the sensor site. Try another type of sensor.
 - Prolonged patient motion may be preventing the N-395 from tracking the pulse. Verify that the sensor is securely applied and replace it if necessary. Change the sensor site. Use a type of sensor that tolerates more patient movement; for example, an adhesive sensor.
 - The sensor may be too tight, there may be excessive ambient light, or the sensor may be on an extremity with a blood pressure cuff, arterial catheter, or intravascular line. Reposition sensor, as necessary.
 - Excessive environmental motion or electromagnetic interference may be preventing the N-395 from tracking the pulse. Remove the source of interference or try to stabilize the environment, or do both.

Other physiological conditions or medical procedures that may interfere with the monitor's measurements include dysfunctional hemoglobin, arterial dyes, and dark pigment.

EMI (ELECTROMAGNETIC INTERFERENCE)

Caution: This device has been tested and found to comply with the limits for medical devices to the IEC 601-1-2:1993, EN 60601-1-2:1994, Medical Device Directive 93/42/EEC. These limits are designed to provide reasonable protection against harmful interference in a typical medical installation.

However, because of the proliferation of radio-frequency transmitting equipment and other sources of electrical noise in healthcare environments (for example, electrosurgical units, cellular phones, mobile two-way radios, electrical appliances, and high-definition television), it is possible that high levels of such interference due to close proximity or strength of a source may result in disruption of performance of this device.

The N-395 is not designed for use in environments in which the pulse can be obscured by electromagnetic interference. During such interference, measurements may seem inappropriate or the monitor may not seem to operate correctly.

Erratic readings, cessation of operation, or other incorrect functioning may evidence disruption. If this occurs, the site of use should be surveyed to determine the source of this disruption, and the following actions taken to eliminate the source:

- Turn equipment in the vicinity off and on to isolate the offending equipment.
- Reorient or relocate the interfering equipment.
- Increase the separation between the interfering equipment and this equipment.

The N-395 generates, uses, and can radiate radio frequency energy and, if not installed and used in accordance with these instructions, may cause harmful interference with other devices in the vicinity.

If assistance is required, contact Mallinckrodt Technical Services Department or your local Mallinckrodt representative.

OBTAINING TECHNICAL ASSISTANCE

The latest version of this manual is available on the Internet at:
http://www.mallinckrodt.com/respiratory/resp/Serv_Supp/ProductManuals.html

For technical information and assistance, or to order parts or a service manual, contact Mallinckrodt Technical Services Department or your local Mallinckrodt representative. The service manual includes block diagrams and a parts list required by qualified personnel when servicing the N-395.

When calling Mallinckrodt Technical Services Department or your local Mallinckrodt representative, you may be asked to tell the representative the software version number of your N-395.

The software version appears in the monitor display each time the monitor successfully completes the power-on self-test. Write the number down and have it available whenever requesting technical assistance.

RETURNING THE N-395

Contact Mallinckrodt Technical Services Department or your local Mallinckrodt representative for shipping instructions including a Returned Goods Authorization (RGA) number. Unless otherwise instructed by Mallinckrodt's Technical Services Department, it is not necessary to return the sensor or other accessory items with the monitor. Pack the N-395 in its original shipping carton. If the original carton is not available, use a suitable carton with appropriate packing material to protect it during shipping.

Return the N-395 by any shipping method that provides proof of delivery.

MAINTENANCE

Service

WARNING: The cover should be removed only by qualified service personnel. There are no user-serviceable parts inside.

Troubleshooting and Maintenance

The N-395 requires no routine service or calibration other than changing the battery at least every 24 months.

If service is necessary, contact qualified service personnel or your local Mallinckrodt representative.

Periodic Safety Checks

It is recommended that the following checks be performed every 24 months.

- Inspect the equipment for mechanical and functional damage.
- Inspect the safety relevant labels for legibility.

Performance Verification

If the monitor has been visibly damaged or subjected to mechanical shock (for example, if dropped), qualified service personnel should perform the procedure in the *Performance Verification* section of the service manual.

Cleaning

WARNING: Do not spray, pour, or spill any liquid on the N-395, its accessories, connectors, switches, or openings in the chassis.

For *surface-cleaning* and *disinfecting* follow your institution's procedures or:

- The N-395 may be *surface-cleaned* by using a soft cloth dampened with either a commercial, nonabrasive cleaner or a solution of 70% alcohol in water, and lightly wiping the surfaces of the monitor.
- The N-395 may be *disinfected* using a soft cloth saturated with 10% chlorine bleach in tap water solution.

Before attempting to clean an SpO₂ sensor, read the directions for use enclosed with the sensor. Each sensor model has cleaning instructions specific to that sensor.

SPECIFICATIONS

Performance
Electrical
Environmental Conditions
Physical Characteristics
Compliance

PERFORMANCE

Measurement Range

SpO ₂	1 - 100%
Pulse Rate	20 - 250 beats per minute (bpm)

Accuracy¹

Saturation (%SpO₂ ±1 SD)

Without Motion:

Adults	70 - 100% ±2 digits
Neonates	70 - 100% ±3 digits
	1 - 69% unspecified

With Motion:²

Adults and Neonates	70 - 100% ±3 digits
	1 - 69% unspecified

¹ Accuracies are expressed as plus or minus "X" digits (oxygen saturation percentage points) between saturation of 70% and 100%. This variation equals plus or minus one standard deviation (1SD), which encompasses 68% of the population. All accuracy specifications are based on testing the subject monitor on healthy adult volunteers in induced hypoxia studies across the specified range. Adult accuracy is determined with Oxisensor II D-25 sensors. Neonatal accuracy is determined with Oxisensor II N-25 sensors.

² For a definition of motion, as applicable to the N-395, contact Mallinckrodt's Technical Services Department.

Specifications

Pulse Rate¹

Without Motion 20 - 250 ±3 digits

With Motion normal physiologic range (e.g., 55 - 125 bpm) ±5 digits

ELECTRICAL

Instrument

Power Requirements	100 - 120 VAC, 200 - 240 VAC, 50/60 Hz, 20 VA switch selectable
Fuses	2 qty, 0.5 A, 250 volts, slow-blow, IEC (5 x 20 mm)

Battery

Type	Lead-Acid
------	-----------

Battery Capacity

A minimum of 2 hours with a new, fully charged battery under the following conditions: no alarms, and no analog or serial output devices attached. A completely discharged battery can be fully recharged in approximately 14 hours while unit is turned off or 18 hours while turned on.

Charge/discharge cycles: at least 400

Sensor

The wavelength range of the light emitted is within the range of 250 nm to 1,000 nm with the energy not exceeding 10 mw.

¹ Pulse Rate accuracy is expressed as plus or minus "X" digits (bpm) across the display range. This variation equals ± one standard deviation (1SD), which encompasses 68% of the population.

ENVIRONMENTAL CONDITIONS

Transport and Storage (in shipping container)

Temperature	-20 to 70°C (-4°F to +158°F)
Altitude/Barometric Pressure	-390 m to 4,572 m (-1280 ft. to 15,000 ft.) 106 kPa to 50 kPa (31.3 in. Hg to +14 in. Hg)
Relative Humidity	15 – 95% noncondensing

Transport and Storage (not in shipping container)

Temperature	-20°C to +60°C (-4°F to +140°F)
Altitude/Barometric Pressure	-390 m to 4,572 m (-1280 ft. to 15,000 ft.) 106 kPa to 50 kPa (31.3 in. Hg to +14 in. Hg)
Relative Humidity	15 – 95% noncondensing over temperature range of -20°C to 60°C (-4°F to +140°F)

Operation

Temperature	+5°C to +40°C (+41°F to +104°F)
Altitude/Barometric Pressure	-390 m to 3,658 m (-1280 ft. to 12,000 ft.) 106 kPa to 70 kPa (+31.3 in. Hg to +20.6 in. Hg)
Relative Humidity	15 – 95% noncondensing

PHYSICAL CHARACTERISTICS

Weight	5.7 lbs.(2.6 kg)
Dimensions	3.3 in. x 10.4 in. x 6 .8 in. (8.4 cm x 26.4 cm x 17.3 cm)

Specifications

COMPLIANCE

Emissions Compliance	EN55011, CISPR 11, Group 1, Class B
Equipment Classification	IEC 60601-1 / CSA 601.1 / UL 2601-1
Type of Protection	Class 1 (on AC power) Internally powered (on battery power)
Degree of Protection	Type BF - Applied part
Enclosure Degree of Ingress Protection from Solids/Liquids	IPX1
Mode of Operation	Continuous
EMI Compatibility	IEC 60601-1-1

QUICK GUIDE TO OPERATION

Introduction
Settings Adjustments

INTRODUCTION

This *Quick Guide to Operation* is intended for use by experienced N-395 users. First-time users of the monitor should read the entire Operator's Manual before use.

To turn the monitor on or off press



SETTINGS ADJUSTMENTS

Table 9 contains the procedures necessary to adjust or view the basic N-395 settings. In general, press EXIT to return to the main menu.

Table 9: Settings Adjustments

To Adjust	Action	Button
Alarm Limits	Press	LIMITS
	Press (to select parameter)	SELECT
	Press	or
	Press	EXIT

Table 9: Settings Adjustments













To Adjust	Action	Button
Alarm Silence Duration	Press and hold (for <i>less</i> than 3 seconds) then, Press	  or 
Alarm Volume	Press and hold (for <i>more</i> than 3 seconds) while continuing to hold, Press	  or 
Baud Rate	Press Press Press Press To select the desired baud rate Press	SETUP  NEXT  COMM   or  EXIT 

Table 9: Settings Adjustments









To Adjust	Action	Button
Bedside Monitor Interface	Press	SETUP 
	Press	NEXT 
	Press	COMM 
	Press	SELECT 
	Press To select AGILENT, SPACECBS, MARQ, or DATEX	 or 
Contrast	Press and hold	
	Press	 or 

Table 9: Settings Adjustments

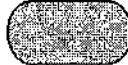









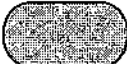

To Adjust	Action	Button
Language	Press	SETUP 
	Press	NEXT 
	Press	LANG 
	Press	 or 
	Press	EXIT EXIT  , 
Pleth or Blip (magnified) View	Press	SETUP 
	Press	VIEW 
	Select	PLETH BLIP  or 
	Press	EXIT 
Pulse Beep Volume	Press and hold	 or 

Table 9: Settings Adjustments















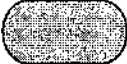

To Adjust	Action	Button
<i>SatSeconds</i>	Press	LIMITS 
	Press	SELECT  to select <i>SatSeconds</i>
	Press	 or 
	Press	EXIT 

Table 9: Settings Adjustments

To Adjust	Action	Button
Time and Date Settings	Press	SETUP 
	Press	CLOCK 
	Press	SET 
	Press (to select setting)	SELECT 
	Press	 or 
	Press (to return to main menu)	EXIT  , EXIT  , EXIT 
Trends	Press	TREND 
	Press	VIEW 
	Select desired view	EXIT 

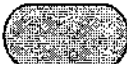
PRINCIPLES OF OPERATION

Oximetry Overview

OXIMETRY OVERVIEW

Pulse oximetry is based on two principles: that oxyhemoglobin and deoxyhemoglobin differ in their absorption of red and infrared light (i.e., spectrophotometry), and that the volume of arterial blood in tissue (and hence, light absorption by that blood) changes during the pulse (i.e., plethysmography). A pulse oximeter determines SpO₂ by passing red and infrared light into an arteriolar bed and measuring changes in light absorption during the pulsatile cycle. Red and infrared low-voltage light-emitting diodes (LEDs) in the oximetry sensor serve as light sources; a photodiode serves as the photodetector.

Because oxyhemoglobin and deoxyhemoglobin differ in light absorption, the amount of red and infrared light absorbed by blood is related to hemoglobin oxygen saturation. To identify the oxygen saturation of *arterial* hemoglobin, the monitor uses the pulsatile nature of arterial flow. During systole, a new pulse of arterial blood enters the vascular bed, and blood volume and light absorption increase. During diastole, blood volume and light absorption reach their lowest point. The monitor bases its SpO₂ measurements on the difference between maximum and minimum absorption (i.e., measurements at systole and diastole). By doing so, it focuses on light absorption by pulsatile arterial blood, eliminating the effects of nonpulsatile absorbers such as tissue, bone, and venous blood.

Automatic Calibration

Because light absorption by hemoglobin is wavelength dependent and because the mean wavelength of LEDs varies, an oximeter must know the mean wavelength of the sensor's red LED to accurately measure SpO₂. During manufacturing, the mean wavelength of the red LED is encoded in a resistor in the sensor.

Principles of Operation

During monitoring, the instrument's software reads this resistor value and selects coefficients that are appropriate for the wavelength of that individual sensor's red LED; these coefficients are then used to determine SpO₂. This resistor value is read when the monitor is turned on, periodically thereafter, and each time a new sensor is connected.

Additionally, to compensate for differences in tissue thickness, the light intensity of the sensor's LEDs is adjusted automatically.

Functional versus Fractional Saturation

This monitor measures functional saturation - oxygenated hemoglobin expressed as a percentage of the hemoglobin that can transport oxygen. It does not detect significant amounts of dysfunctional hemoglobin, such as carboxyhemoglobin or methemoglobin. In contrast, hemoximeters such as the IL482 report fractional saturation - oxygenated hemoglobin expressed as a percentage of all measured hemoglobin, including measured dysfunctional hemoglobins. To compare functional saturation measurements to those from an instrument that measures fractional saturation, fractional measurements must be converted as follows:

$$\text{functional saturation} = \frac{\text{fractional saturation}}{100 - (\% \text{ carboxyhemoglobin} + \% \text{ methemoglobin})} \times 100$$

Measured versus Calculated Saturation

When saturation is calculated from a blood gas partial pressure of oxygen (PO₂), the calculated value may differ from the SpO₂ measurement of a pulse oximeter. This usually occurs because the calculated saturation was not appropriately corrected for the effects of variables that shift the relationship between PO₂ and saturation (Figure 21): pH, temperature, the partial pressure of carbon dioxide (PCO₂), 2,3-DPG, and fetal hemoglobin.

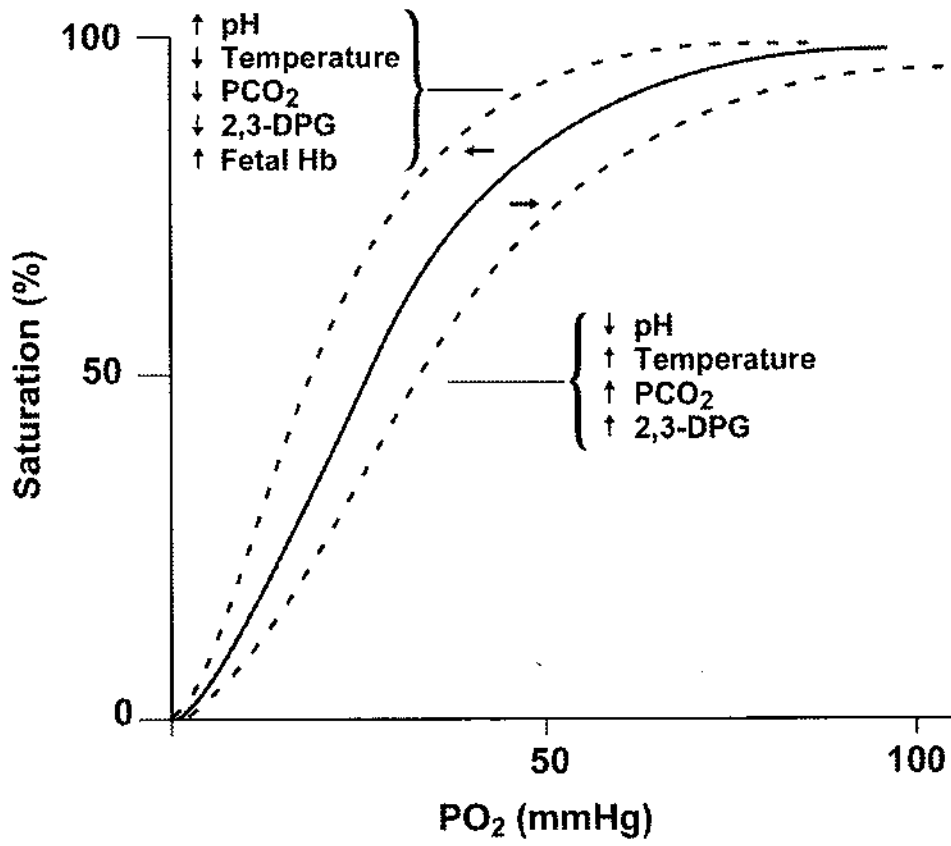

Figure 21: Oxyhemoglobin Dissociation Curve

DATA PORT PROTOCOL

- Overview
- Connecting to the Data Port
- Baud Rate
- Setting Data Port Protocol
- Real-Time Display Format
- Trend Data Printout (ASCII Mode)
- Trend Data Printout (Graph Mode)
- Nurse Call
- Analog Outputs

OVERVIEW

Patient data can be obtained through the data port on the back of the N-395 by connecting it to an attached PC or serial printer.

When connecting the N-395 to a printer or PC, verify proper operation before clinical use. Both the N-395 and the printer or PC must be connected to a grounded AC outlet. The N-395 protocol setting must be in the ASCII mode as described in the "COMM" paragraph of the *Start-Up and Use* section.

Any printer or PC connected to the monitor's data port must be certified according to IEC Standard 950. All combinations of equipment must be in compliance with IEC Standard 601-1-1 systems requirements. Anyone who connects a printer or PC to the data output port configures a medical system and is therefore responsible for ensuring that the system complies with the requirements of system standard IEC Standard 601-1-1 and the electromagnetic compatibility system standard IEC Standard 601-1-2.

CONNECTING TO THE DATA PORT

The N-395 data port may be connected to the printer or PC by using a cable terminated with an AMP connector (AMP part number 747538-1), ferrule (AMP part number 1-747579-2), and compatible pins (AMP part number 66570-2). The cable should be no more than 25 feet (7.6 meters) in length. The external ITE

Data Port Protocol

(Information Technology Equipment) device must be certified to UL-1950 or IEC-60950.

The cable used must have a braided shield providing 100% coverage, such as a Belden cable (Belden part number 9609) or equivalent. The shield must have a 360-degree connection to the metal shell on the N-395's DB-15 connector and to the connector on the PC or serial printer. Do not create sharp bends in the cable, as this may tear or break the shielding.

The pinouts (as illustrated in Figure 22) for the data port are listed in Table 10.

Table 10: Data Port Pinouts

Pin	Signal Name
1	RxD+ (RS-422[+] input)
2	RxD_232 (RS-232 input)
3	TxD_232 (RS-232 output)
4	TxD+ (RS-422[+] output)
5	Signal Ground (isolated from Earth Ground)
6	AN_SpO ₂ (analog saturation output)
7	NC_NO (relay closure nurse call, normally open)
8	NC_NC (relay closure nurse call, normally closed)
9	RxD- (RS-422 [-] input)
10	Signal Ground (isolated from Earth Ground)
11	Nurse Call (232-level output)
12	TxD- (RS-422 [-] output)
13	AN-PULSE (analog pulse rate output)
14	AN-PLETH (analog pleth wave output)
15	NC-COM (relay closure nurse call common lead)

GND is ground, TxD represents the Transmit Data line, and RxD is the Receive Data line.

The pin layouts (as viewed from the rear panel of the N-395) are illustrated in Figure 22. The conductive shell is connected to earth ground when connected to a PC or printer.

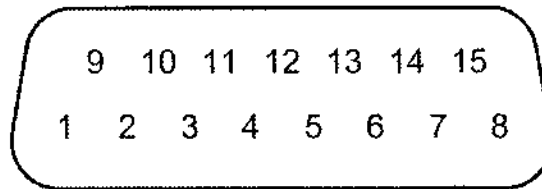

Figure 22: Data Port Pin Layout

Pins 2, 3, and 5 provide data in RS-232 format.

Pins 1, 4, 9, and 12 provide data in RS-422 format. TxD+ and TxD- are the differential transmit data pair. RxD+ and RxD- are the differential receive pair.

No hardware flow control is used. However, in the ASCII mode XON/XOFF flow control is supported.

BAUD RATE

Pressing the SETUP softkey and then the COMM softkey can change the baud rate. Use the ADJUST UP/DOWN Buttons to select a baud rate of 2400, 9600, or 19200, depending on the capabilities of the attached equipment.

SETTING DATA PORT PROTOCOL

The available data port protocols are:

- ASCII
- OXINET
- CLINICAL
- GRAPH
- AGILENT – Agilent (HP) communications
- SPACELBS – SpaceLabs communications
- MARQ – GE Marquette communications
- DATEX – Datex-Ohmeda AS/3 communications

Data Port Protocol

Note: Selections for Agilent, SpaceLabs, GE Marquette, and Datex are included in N-395 software versions 1.7 and higher.

The protocol settings allow the N-395 to communicate with various devices. ASCII is used during normal operation and for serial printers. GRAPH is used for graphical trend printouts when connected to a serial printer that supports Epson ESC protocol. Select OXINET when connecting to an *Oxinet® II* central station network or Score software. The Bedside Monitor Interface selections are AGILENT (for Agilent HP monitors), SPACELBS (for SpaceLab monitors), MARQ (for Marquette monitors), and DATEX (for Datex-Ohmeda AS/3 monitors). Do not use the CLINICAL setting unless instructed to do so by Mallinckrodt's Technical Services personnel.

REAL-TIME DISPLAY FORMAT

While the N-395 data port protocol setting is set to ASCII (refer to *Start-Up and Use* section), real-time data is continuously sent to the data port on the back of the N-395. Patient data can be obtained through the data port by connecting it to an attached PC or serial printer. When a real-time printout or display is being transmitted to a printer or PC, a new line of data is displayed every 4 seconds. Column headings will be displayed or printed after every 25 lines, or if one of the values in the column heading changes.

Note: If the data output stops transmitting, turn the power off and back on again or, if connected to a PC, send an XON (Ctrl-q) to reset the monitor.

An example of a real-time printout is shown in Figure 23.

N-395	VERSION 2.0.0.0	CRC: XXXX	SpO2 Limit: 70-100%	PR Limit: 60-160BPM
TIME	%SpO2	BPM	PA	Status
12-NOV-99 14:00:05	100	120	50	
12-NOV-99 14:00:07	100	124	50	
12-NOV-99 14:00:09	100	190*	52	PH
12-NOV-99 14:00:11	100	190*	50	PH
12-NOV-99 14:00:13	100	190*	51	PH
12-NOV-99 14:00:15	100	190*	50	PH
12-NOV-99 14:00:17	100	190*	50	PH
12-NOV-99 14:00:19	100	190*	51	PH
12-NOV-99 14:00:21	100	190*	53	PH LB
12-NOV-99 14:00:23	100	190*	50	PH LB
12-NOV-99 14:00:25	100	190*	50	PH LB
12-NOV-99 14:00:27	---	---	---	SD LB
12-NOV-99 14:00:29	---	---	---	SD LB
12-NOV-99 14:00:31	---	---	---	SD
12-NOV-99 14:00:33	---	---	---	SD
12-NOV-99 14:00:35	---	---	---	SD
12-NOV-99 14:00:37	---	---	---	SD
12-NOV-99 14:00:39	---	---	---	SD
12-NOV-99 14:00:41	---	---	---	SD
12-NOV-99 14:00:43	---	---	---	SD
12-NOV-99 14:00:45	---	---	---	SD
12-NOV-99 14:00:47	---	---	---	SD
12-NOV-99 14:00:49	---	---	---	SD
N-395	VERSION 2.0.0.0	CRC: XXXX	SpO2 Limit: 70-100%	PR Limit: 60-160BPM
TIME	%SpO2	BPM	PA	Status
12-NOV-99 14:00:51	---	---	---	SD
N-395	VERSION 2.0.0.0	CRC: XXXX	SpO2 Limit: 70-100%	PR Limit: 60-160BPM
TIME	%SpO2	BPM	PA	Status
12-NOV-99 14:00:53	79*	59*	50	SL PL LB
12-NOV-99 14:00:55	79*	59*	50	PS SL PL LB

Figure 23: Real-Time Printout

Column Headings

Every 25th line of the data is a column heading.

N-395	VERSION 2.0.0.0	CRC: XXXX	SpO2 Limit: 70-100%	PR Limit: 60-160BPM
TIME	%SpO2	BPM	PA	Status

A column heading is also displayed whenever a value of the column heading is changed. There are three column heading lines shown in Figure 23. Using the top row as the starting point there are 25 lines before the second column heading is printed. The third column heading was displayed because the SpO2 limits changed from 70-100% to 80-100%.

Data Port Protocol

Data Source

N-395	VERSION 2.0.0.0	CRC: XXXX	SpO2 Limit: 70-100%	PR Limit: 60-160BPM
TIME	%SpO2	BPM	PA	Status

Data in the highlighted box above represents the model number of the monitor, in this case the N-395.

Software Revision Level

N-395	VERSION 2.0.0.0	CRC: XXXX	SpO2 Limit: 70-100%	PR Limit: 60-160BPM
TIME	%SpO2	BPM	PA	Status

The next data field tells the user the software level, (Version 2.0.0.0) and a software verification number (CRC: XXXX). Neither of these numbers should change during normal operation. The numbers may change if the monitor is serviced and receives a software upgrade.

Alarm Limits

N-395	VERSION 2.0.0.0	CRC: XXXX	SpO2 Limit: 70-100%	PR Limit: 60-160BPM
TIME	%SpO2	BPM	PA	Status

The last data field in the top line indicates the high and the low alarm limits for %SpO₂ and for the pulse rate (PR). In the example above the low alarm limit for SpO₂ is 70% and the high alarm limit is 100%. Pulse Rate alarm limits are 60 and 160 bpm.

Column Headings

N-395	VERSION 2.0.0.0	CRC: XXXX	SpO2 Limit: 70-100%	PR Limit: 60-160BPM
TIME	%SpO2	BPM	PA	Status

Actual column headings are in the second row of the column heading line. Patient data presented in the chart, from left to right, is the:

- time the patient data was obtained
- current %SpO₂ value
- current Pulse Rate
- current Pulse Amplitude
- operating status of the N-395.

Patient Data and Operating Status

Time

TIME	%SpO2	BPM	PA	Status
12-NOV-99 14:00:05	100	120	50	

The Time column represents the N-395 real-time clock.

Patient Data

N-395	VERSION 2.0.0.0	CRC: XXXX	SpO2 Limit: 70-100%	PR Limit: 60-160BPM
TIME	%SpO2	BPM	PA	Status
12-NOV-99 14:00:05	100	120	50	

Patient data is highlighted in the display above. Parameter values are displayed directly beneath the heading for each parameter. In this example the %SpO₂ is 100, and the pulse rate is 190 beats per minute. The "*" next to the 190 indicates that 190 beats per minute is outside of the alarm limits, indicated in the top row, for pulse rate. If no data for a parameter is available three dashes (- - -) will be displayed.

PA is an indication of pulse amplitude. The number can range from 0 to 254. There are no alarm parameters for this value. It can be used for trending information as an indication of a change in pulse volume, relative pulse strength, or circulation.

Operating Status

N-395	VERSION 2.0.0.0	CRC: XXXX	SpO2 Limit: 70-100%	PR Limit: 60-160BPM
TIME	%SpO2	BPM	PA	Status
12-NOV-99 14:00:11	100	190*	50	PH

The Status column indicates alarm conditions and operating status of the N-395. In this example, the PH means that the pulse rate upper alarm limit (Pulse High) has been exceeded. A complete listing of the status codes is listed in Table 11. As many as 4 codes can be displayed at one time in the Status column.

Table 11: Status Codes

Code	Meaning
AO	Alarm Off
AS	Alarm Silence
LB	Low Battery
LM	Loss of Pulse w/ Motion
LP	Loss of Pulse
MO	Patient Motion
PH	Pulse Rate High Limit Alarm
PL	Pulse Rate Low Limit Alarm
PS	Pulse Search
SH	Sat High Limit Alarm
SL	Sat Low Limit Alarm
SD	Sensor Disconnect

Note: A sensor disconnect will also cause three dashes (- - -) to be displayed in the patient data section of the display or printout.

TREND DATA PRINTOUT (ASCII MODE)

The format of data displayed when a trend printout (Figure 24) is requested is similar to that of the real-time data. The only differences are that “TREND” is displayed in the top row instead of the “CRC: XXXX” software verification number and there is no “Status” column.

Readings are displayed in 4-second intervals. The values on each row are an average for the 4-second period.

At the end of the printout an “Output Complete” line indicates that the transmission was successful. If the “Output Complete” line is not present, a corruption of the data may have been detected and the data should be ignored.

N-395	VERSION 2.0.0.0	TREND	SpO2 Limit: 70-100%	PR Limit: 60-160BPM
TIME	%SpO2	BPM	PA	Status
12-NOV-99 14:00:05	100	120	150	
12-NOV-99 14:00:07	100	121	154	
12-NOV-99 14:00:09	100	120	150	
Output Complete				

Figure 24: Trend Data Printout (ASCII MODE)

Once a trend printout has begun, it cannot be aborted without turning off the N-395 or the printer.

TREND DATA PRINTOUT (GRAPH MODE)

The graph mode (Figure 25) disables all printout functions except trend data. Trend printouts will be graphical if connected to an approved serial printer. Contact Mallinckrodt's Technical Services Department for a list of approved serial printers.

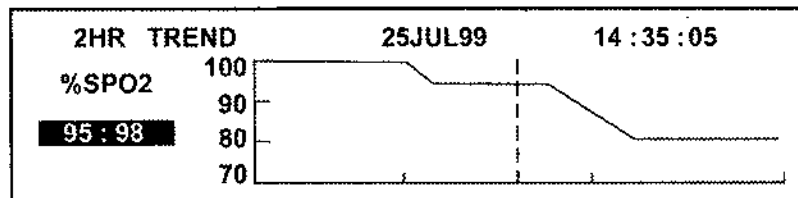

Figure 25: Trend Data Printout (GRAPH MODE)

NURSE CALL

WARNING: The nurse call feature should not be used as the primary source of alarm notification. The audible and visual alarms of the monitor, used in conjunction with clinical signs and symptoms, are the primary source for notifying medical personnel that an alarm condition exists.

The N-395 provides two different types of nurse call interfaces: an RS-232 level and solid state relay closure. The solid state relay-based nurse call function is available when the monitor is operating either on AC power or when powered by battery.

The remote location will be signaled anytime there is an audible alarm.

Pin 11 on the data port is the RS-232 level nurse call signal and pin 10 is ground (see Table 10). The nurse call polarity (normally high or normally low) and whether the monitor is in

alarm determine the voltage between these pins. The nurse call polarity is set by using the procedures in the *Start-up and Use* section. To access the nurse call menu from the main menu, press softkeys SETUP, NEXT, NEXT and NCALL.

When the nurse call polarity setting is normally high (NORM +) and there is no alarm condition, the voltage between pins 11 and 10 will be +5 to +12 volts DC. Whenever the monitor is in an alarm condition, the output between pins 11 and 10 will be -5 to -12 volts DC. When the setting is normally low (NORM -), the readings are opposite, as indicated in Table 12.

These voltages are present only when the monitor is operating on AC power.

If the audible alarm has been turned off, or silenced, the nurse call alarm is also silenced.

Table 12: Voltage Between Pins 10 and 11

Alarm State	Nurse Call Polarity Setting	Voltage from pins 10 to 11
No current alarms	Normally high	+5 to +12 VDC
Alarm condition	Normally high	-5 to -12 VDC
No current alarms	Normally low	-5 to -12 VDC
Alarm condition	Normally low	+5 to +12 VDC

Pins 7 and 15 provide a solid state relay that closes when an alarm is sounding on the monitor. Pins 8 and 15 provide a solid state relay that opens when an alarm is sounding. Pin 15 is a common lead for both relays. The solid state relay operates whether the monitor is operating on AC power or battery.

ANALOG OUTPUTS

The N-395 data port also provides analog voltage outputs between pins 6, 13, 14, and ground (pins 5 or 10), which can be used to calibrate instruments such as a chart recorder. The voltage represents a specific measured parameter's current value. The voltage differential varies proportionally from 0 to 1 volt as the pin's parameter varies over its full range of values, as indicated in Table 13.

Table 13: Analog Pinouts

Pin	Parameter	Parameter Range
6	%SpO ₂	0 - 100%
13	Pulse rate	0 - 250 bpm
14	Pleth wave	0 - 255

For example, as the current value of %SpO₂ varies from 0 to 100%, the voltage from pin 6 to ground (pin 10) would vary from 0 to 1 volt. A voltage of .94 volts indicates a current %SpO₂ value of 94.

The analog output calibration function can be accessed from the main menu by pressing SETUP, NEXT, NEXT, ANALOG. Selecting "0 VOLT" or "1 VOLT" causes that voltage to appear at pins 6, 3, or 10. Selecting "STEP" causes the voltage to increase from 0 to 1 volt at 1/10th-volt increments, with each step lasting at least 1 second.

Qualified service personnel using the procedure described in the N-395 service manual can perform calibration of the analog output and the attached device.

INDEX

A

40-Second Trend Table · 50

A

Accessories · 12
Adjustable
 Settings · 38
Agilent (HP) Communications · 54
Alarm Limits
 Changing · 43
 Viewing Current · 42
Alarm Limits Changed Indicator · 46
Alarm Management
 SatSeconds · 35
Alarm Silence Duration · 39
Alarm Silence Reminder · 40
Alarm Volume · 39
Alarms
 Description · 34
 High-Priority · 34
 Low-Priority · 34
 Medium-Priority · 34
ANALOG · 58
Analog Output · 97
ASCII Mode · 94
ASCII MODE · 51
Automatic Shutdown · 33

B

Basic Operation · 28
Battery Operation · 61
Biocompatibility Testing · 24
Buttons
 Adjust Down · 7
 Adjust Up · 7
 Alarm Silence · 7
 Contrast · 7

Power On/Off · 7
Softkey · 7

C

Changing Alarm Limits · 43
Cleaning · 72
CLOCK · 52
Codes
 Error · 65
COMM · 53
Connecting the N-395 · 19
Connecting to the Data Port · 87
Contrast · 31
Corrective Actions · 67

D

Data Port
 Baud Rate · 89
 Connection To · 87
 Pin Layout · 89
 Pinouts · 88
Data Port Protocol · 87
Datex Communications · 57
Default Settings · 58
DELETE · 51
Disabling Audible Alarms · 40
Discharged Battery · 19
Display Format
 Real-Time · 90
Disposal of Device Components · 62

E

EMI Interference · 70
Error Codes · 65

Index

F

Front Panel · 5

G

GCX Mounting Plate · 13
GCX Poly-mount · 14, 15
GCX Roll Stand Poly-mount · 16
GCX Utility Basket · 17
GRAPH MODE · 52

H

Histogram · 49

I

Inaccurate measurements · 25, 63
Indicators
 AC Power · 8
 Alarm Limits Changed · 46
 Alarm Silence · 9
 Alarm Silence Reminder · 10
 Confirmation Tone · 10
 High Priority Alarm · 9
 Invalid Button Pressed · 9
 Low Battery · 8
 Low Priority Alarm · 10
 Medium Priority Alarm · 9
 Motion · 9
 Percent SpO₂ · 8
 Power-On Self-Test Passed · 9
 Pulse Amplitude · 8
 Pulse Beep · 10
 Pulse Rate · 8
 Pulse Search · 9
 SatSeconds · 9
 Valid Button Press · 9
 Volume Setting Tone · 10
Initial Power-Up · 32
Inspection · 11
Intended Use · 3

L

LANG · 57
Language Selection · 21
LIGHT · 58
Limits · 42
Limits Menu · 43
Loss-of-pulse · 25
Low Battery Indicator · 61
Low Peripheral Perfusion · 26

M

Maintenance · 72
Marquette Communications · 56
Menu Structure · 41
Messages
 Disallowed on Battery · 67
 Disallowed on Low Battery · 67
 Invalid Silence Duration · 67
 Invalid SpO₂ Limit · 67
 Reading Trend · 67
 Sensor Disconnected · 66
 Sensor Off · 67
Monitor Setup · 19
Monitoring Mode · 31

N

NCALL · 58
NEXT · 51
Nurse Call · 60, 95

O

Obtaining Technical Assistance · 71
Operating Conditions · 3
Operating Principles · 3
Operation
 Battery · 61
Oximetry Overview · 83

P

Packing List · 11
Patient Considerations
 Impact of Readings · 62
Patient Movement · 26
Performance Considerations · 25, 62
Performance Verification · 11, 72
Periodic Maintenance · 72
Poor Perfusion · 26
Power-On Self-Test (POST) · 28
Principles of Operation · 83
PRINT · 51
Printout
 Alarm Limits · 92
 ASCII Mode · 94
 Column Headings · 91
 Data Source · 92
 GRAPH Mode · 95
 Operating Status · 93
 Patient Data · 93
 Software Revision Level · 92
Pulse Beep Volume · 38
Pulse Search · 32

Q

Quick Guide to Operation · 77

R

Real-Time Display Format · 90
Real-Time Printout · 91
Rear Panel · 6
Returning the N-395 · 71

S

Safety Checks · 72
Safety Information · 1
SatSeconds
 Alarm Management · 35
 Determining Setting · 37

 Display · 38
 Safety Net · 37
Saturation
 Calculated · 84
 Fractional · 84
 Functional · 84
 Measured · 84
Selecting a Sensor · 23
Sensor
 Selection · 23
Sensor Disconnected · 33
Sensor Off · 33
Sensors · 23
Service · 72
Settings
 Adult-Pediatric · 30
 Adjustable · 38
 Alarm Silence Duration · 39
 Alarm Silence Reminder · 40
 Alarm Volume · 39
 Default · 58
 Disabling Audible Alarms · 40
 Neonatal · 30
 Pulse Beep Volume · 38
SETUP · 52
Setup Menu · 45
Soft Sided Carrying Case · 18
Softkeys
 ANALOG · 58
 CLOCK · 52
 COMM · 53
 DELETE · 51
 LANG · 57
 LIGHT · 58
 NCALL · 58
 NEXT · 51
 PRINT · 51
 SETUP · 52
 VIEW · 52
 ZOOM · 50
Software Revision Level · 92
SpaceLabs Communications · 55
Specifications · 73
 Accuracy · 73
 Compliance · 76
 Electrical · 74
 Environmental Conditions · 75
 Measurement Range · 73
 Performance · 73
 Physical Characteristics · 75

Index

Pulse Rate · 74
SpO2 · 73
Start Up and Use · 27
Status Codes · 94

Symbols

Date of Manufacture · 6
Equipotential (Ground) Terminal · 6
Fuse Replacement · 6
See Instructions · 6
Type BF Equipment · 6

Symbops

Data Interface · 6

T

Taking Measurements · 33
Technical Assistance · 71
Trend · 46
 Histogram · 49
 View · 48
 ZOOM · 50
Trend Data Printout (ASCII Mode) ·
 94
Trend Data Printout (GRAPH Mode) ·
 95
Trend Menu · 44

Trend Scale · 47

Trends

40-Second Trend Table · 50
Troubleshooting · 65

U

Unpacking · 11

V

Verification

Performance · 11, 72
View · 52
 Trend · 48
Viewing Current Alarm Limits · 42
Voltage Selector Switch · 19

Z

ZOOM · 50
