

The Hall® Series 4® Instruction Manual

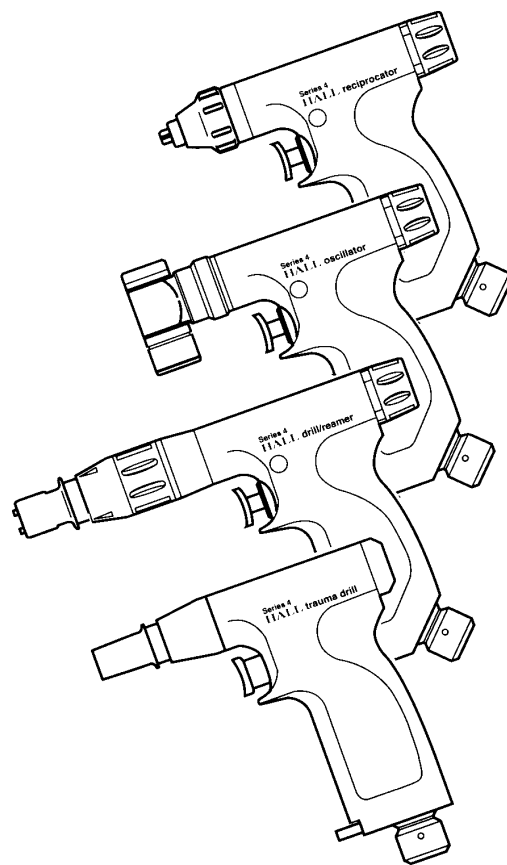

Hall® Surgical

Proprietary Information

This manual contains information deemed proprietary to Linvatec Corporation. The information contained herein, including all of the designs and related materials, is the sole property of Linvatec and/or its licensors. Linvatec and/or its licensors reserve all patent, copyright and other proprietary rights to this document, including all design, manufacturing methodology and reproduction.

This document, and any related materials, is confidential and is protected by copyright laws and shall not be duplicated, transmitted, transcribed, stored in a retrieval system, or translated into any human or computer language in any form or by any means, electronic, mechanical, magnetic, manual or otherwise, or disclosed to third parties, in whole or in part, without the prior express written consent of Linvatec.

Linvatec reserves the right to revise this publication and to make changes from time to time in the contents hereof without obligation to notify any person of such revision or changes, unless otherwise required by law.

© Linvatec Corporation 2000. All Rights Reserved. Printed in USA

Record the Model and Serial Numbers of the handpiece(s), and date received. Retain for future reference.

Handpiece Model No. _____ Serial No _____ Date _____

Handpiece Model No. _____ Serial No _____ Date _____

Handpiece Model No. _____ Serial No _____ Date _____

Handpiece Model No. _____ Serial No _____ Date _____

Table of Contents

Page

1.0 INTRODUCTION

1.1 Intended Use3
1.2 General Warnings3

2.0 INSTALLATION and OPERATION

2.1 Power Source and Regulator Installation and Operation5
2.2 Equipment Installation and Operation8
 2.2.1 Drill/Reamer9
 2.2.1.1 Connecting Attachments10
 2.2.1.2 Mode Selection and Operation.....11
 2.2.2 Oscillating Saw12
 2.2.2.1 Blade Attachment Instructions.....12
 2.2.2.2 Rotating Head Instructions.....14
 2.2.2.3 Operating Instructions14
 2.2.3 Reciprocating Saw15
 2.2.3.1 Blade Attachment and Operation Instructions15
 2.2.4 Trauma Drill17
 2.2.4.1 Connecting Attachments17
 2.2.4.2 Mode Selection and Activation19

Table of Contents

Page

3.0 MAINTENANCE

3.1	Cleaning and Sterilizing	20
3.1.1	Care and Cleaning Precautions	20
3.1.2	Cleaning Instructions	20
3.1.3	Sterilization	21
3.1.3.1	Pre-Vacuum Steam Sterilization	22
3.1.3.2	Gravity Air Displacement Steam Sterilization	22
3.2	Troubleshooting	23
3.3	Specifications	27
3.3.1	Drill/Reamer Handpiece	27
3.3.2	Trauma Drill Handpiece	27
3.3.3	Oscillating Saw	28
3.3.4	Reciprocating Saw	28
3.3.5	Environmental Requirements	29

4.0 CUSTOMER SERVICE and WARRANTY

4.1	Customer Service	30
4.2	Attachments and Accessories	32
4.3	Linvatec and Hall [®] Surgical Instrument Warranty	34

1.0 INTRODUCTION

It is recommended that personnel study this manual before attempting to operate, clean or sterilize the Hall[®] Series 4[®] Handpieces. The safe and effective use of this equipment requires the understanding of and compliance with all warnings, caution notices and instructions marked on the product and included in this manual.

1.1 Intended Use

The intended use for the Hall Series 4 handpieces is in large bone surgery.

1.2 General Warnings

1. This equipment is designed for use only by medical professionals who are completely familiar with the required techniques and instructions for use of the equipment. Read and follow all warnings and caution notices and instructions marked on the product and included in this manual.
2. Eye protection is recommended when operating equipment. 
3. Use only Linvatec[®] and Hall[®] accessories and attachments.
4. Prior to each use, perform the following:
 - Inspect all equipment for proper operation.
 - Ensure all attachments, accessories and hoses are correctly and completely attached to the handpiece.
 - Always inspect hoses for signs of wear or damage. Do not use worn or damaged hoses. Replace immediately.
 - Check all equipment for any air or nitrogen leakage. If leakage is noticed, return for service.
5. Handle all equipment carefully. Should a handpiece or attachment be dropped or damaged in any way, return it immediately for service.
6. Put the instrument in the “SAFE” position before changing blades, bits, accessories or hoses, and when the instrument is not in use. Accidental activation of the instrument could cause injury.

7. Always inspect for bent, dull or damaged blades or drill bits before each use. Do not attempt to straighten or sharpen. After use, dispose of properly.
8. Dull bits and blades may cause heat build-up in the handpiece and the bone. It is recommended that single-use bits and blades be used. If reusable bits or blades are used, inspection with a magnifying glass should be performed to check for dulled and chipped cutting surfaces.
9. Continually check all parts of the instrument or its attachments for overheating. If overheating is noticed, discontinue use and return the equipment for service.
10. Do not pressurize hoses until all fittings have been connected and checked.
11. Never operate instrument above 100 psi (7 kg/cm²) dynamic pressure unless an extension hose is added to the standard 10 foot hose. Excessive pressure may cause damage to instrument and exert unusual stress on the hose.
12. Use the appropriate mode selection for the appropriate function.
 - Never drive bone screws with the Drill/Reamer in the “REAM” or “DRILL” position.
 - Always use the “SCREW” position for tapping threads and seating screws.
13. The nitrogen regulator is for use with pneumatically powered surgical devices only.
14. Do not lubricate any Series 4 handpiece or accessory.
15. After each use, thoroughly clean and sterilize handpieces and accessories (See **“Cleaning and Sterilizing” on page 20**).

2.0 INSTALLATION and OPERATION

2.1 Power Source and Regulator Installation and Operation

WARNING: Not for inhalation. Does not support life. For use with powered surgical devices only.

Research and experience have shown that water-pumped dry nitrogen is the ideal source for pneumatically-powered surgical instruments. Water-pumped dry nitrogen is 99.97% pure, and will not support combustion or corrosion. Compressed dry nitrogen is recommended as the pneumatic power source. It is available in standard cylinders.

Compressed dry nitrogen must meet the following specifications to ensure optimum safety for both patient and instrument.

Nitrogen Content: 99.97% pure, dry nitrogen.

Quality Assurance: To obtain the quality of gas needed, “water-pumped dry nitrogen, or liquid nitrogen, pumped dry” should be specified.

Nitrogen is readily available from gas supply houses in **H** cylinders holding slightly more than 300 cubic feet (8.50 cubic meters). Initial set-up costs are relatively inexpensive as compared to compressed air. Nitrogen can be placed in the operating room or in a storage area and piped into the operating room. Manifold systems are available to eliminate frequent tank changes.

CAUTION: Do not exceed 100 psi (7 kg/cm²) operating pressure unless a hose longer than the standard 10 ft. Universal Hose (5052-010) or extension hose is used. Add an additional 1 psi for every extra foot of hose.

The Series 4 handpieces should be operated at 100 psi (7 kg/cm²) for maximum operating efficiency, and should be monitored by the operating pressure gauge of the regulator. Lower pressure setting can be set for lower speed and torque requirements. Pressure must be set with the instrument running to ensure proper operating pressure.

Never start a procedure if the operating pressure gauge indicates less than 500 psi (35.1 kg/cm²) in the tank. Never run the tank pressure below 200 psi (14.0 kg/cm²).

The tank should be thoroughly wiped off with disinfectant and draped prior to placement in the operating room. Always have the tank securely fastened to a stable object.

1. Prior to set-up in the operating room, open the tank valve (counterclockwise) slowly and allow enough gas to escape to blow out any debris that may have accumulated in the valve. Stay clear of the opening and the back of the tank during this procedure. Return the valve to the closed position.



2. Install the regulator with a 1 1/8 inch wrench.



NOTE: The threaded adaptor of the nitrogen regulator is designed to fit nitrogen fittings only. Incompatibility of the regulator and tank indicates a gas source other than nitrogen or an improper regulator for use with a nitrogen tank.

3. Once the regulator is securely installed, ensure the regulator knob is in the full off position by turning the regulator control knob counterclockwise. **SUDDEN PRESSURE EXERTED TO THE REGULATOR MAY CAUSE INTERNAL DAMAGE.**



4. Slowly turn the tank valve fully open (counterclockwise). This will allow nitrogen to pressurize the regulator.



5. Insert the male Schrader end of the hose into the female Schrader on the regulator with an upward thrust.



6. Operating pressure is established by gradually turning the regulator control knob clockwise. **ALWAYS establish the designated pressure on the operating pressure gauge with the instrument running.**



7. Before removing the instrument from the regulator:
 - (a) Close the tank valve by turning it clockwise.
 - (b) Activate the instrument to bleed off line pressure.
 - (c) Turn the pressure regulator knob counterclockwise until it stops.
 - (d) Turn the female Schrader to the right to disengage the male Schrader fitting.
 - (e) The hose can then be removed from the connector. Hold the end of the hose securely when disengaging the male Schrader fitting to prevent possible damage to the diffuser.

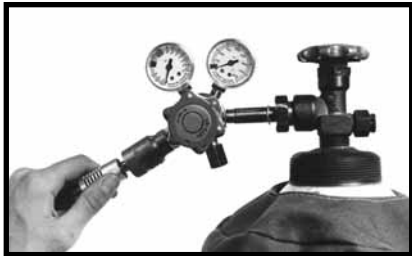

8. If the Hall Pneumatic Connector* is being used:
 - (a) Locate the button marked "PRESS".
 - (b) Depress and hold the button until the audible release of residual gas is completed.



- (c) Release the button and remove the hose.
- (d) If the hose cannot be easily removed, depress the "PRESS" button again, release it and remove the hose.

* U.S. Patent 4,863,201

2.2 Equipment Installation and Operation

1. Place the handpiece in the "SAFE" position.



2. To connect the handpiece to the hose.
 - (a) Insert the coupling end of the hose into the fitting on the bottom of the handpiece.



- (b) Twist the hose coupling to the right (clockwise) and slightly pull on the hose so the internal pins securely engage in the indentations.

3. Attached to the Universal Hose (5052-010) is the Hall Hose Handler*. This clip allows fixation of the hose to the surgical drape, reducing the problem of the hose slipping off the patient.



4. The Velcro® strap allows the hose to be coiled, thus reducing excess hose length. In addition, the VELCRO strap may be used with any additional hose and/or cable.

* U.S. Patent 4,639,980

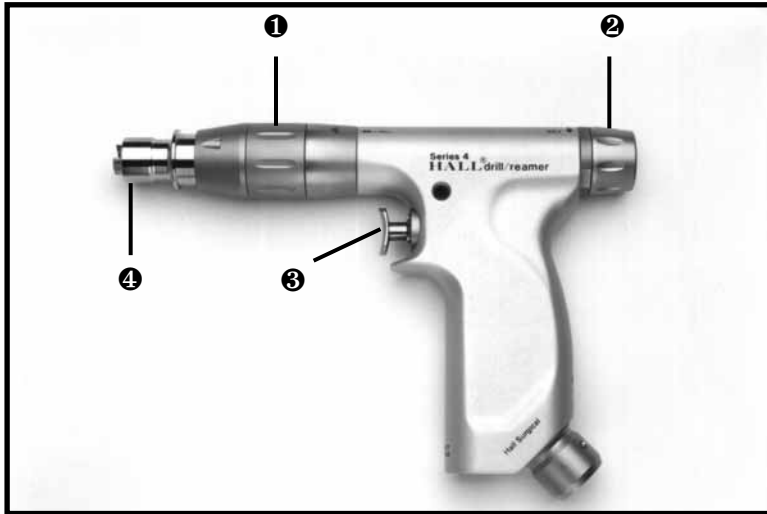

2.2.1 Drill/Reamer

- ❶ **Mode Selector** - Used to select the operating mode of the handpiece between “DRILL” “SCREW” and “REAM”.

“DRILL” Position: Used for Drilling and Pin Insertion.

“REAM” Position: Used for Femoral Reaming, Acetabular Reaming and Pin Insertion.

“SCREW” Position: Used for Tapping and Setting Bone Screws.

- ❷ **Direction Control Knob** - Used to select the operating direction between “FWD” (forward) “REV” (reverse) and “SAFE”.

Place the control knob in the “SAFE” position when changing accessories. To activate the handpiece, place the control knob in either “FWD” or “REV”.

- ❸ **Activation Trigger** - Used to activate the handpiece when the direction control knob is in either “FWD” or “REV”.

- ❹ **Zimmer/Hudson Snap-Lock Chuck** - Used to quickly attach accessories.

2.2.1.1 Connecting Attachments

The Drill/Reamer Handpiece has a combination collet which will accept all the illustrated shank styles below, without the need for an adaptor. AO shanked products (not pictured) may also be used with the Drill/Reamer Handpiece, utilizing the Zimmer to AO Adaptor.



Trinkle shank accessories must utilize the Zimmer to Trinkle adaptor. Affix the Trinkle adaptor into the Zimmer/Hudson snap-lock chuck as described in step 1.



AO Shank accessories must utilize the AO adaptor. Affix the AO adaptor into the Zimmer/Hudson snap-lock chuck as described in step 1.



1. To connect attachments:
 - (a) Place the Direction Control Knob in the "SAFE" position.



- (b) Firmly grasp the chuck and pull back toward the handpiece.

When inserting Trinkle or AO products, care should be taken to pull back on the adaptor itself, not the handpiece snap-lock chuck.



- (c) Insert the shank of the attachment into the chuck, then release the chuck.

NOTE: Be certain the Trinkle or AO Adapter is properly seated. When properly affixed, the inner housing will be flush with the outer housing.

The Drill/Reamer is cannulated and will accept pins up to 0.156 inch diameter or 4.0mm.



2. To attach the Torque Control Handle to the instrument:

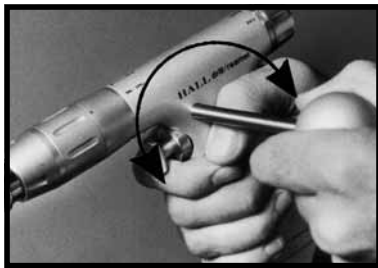

- (a) Insert the handle into the torque control receptacle on the side of the handpiece.
 - (b) Twist the Torque Control Handle until it locks securely into position.
3. The Torque Control handle is easily removed by twisting and pulling out on the handle.

NOTE: Securely attach the torque control handle when using heavy reamers or attachments. The torque control handle will assure maximum control of the handpiece.

2.2.1.2 Mode Selection and Operation

WARNINGS:

1. Always make sure you are in the proper mode before the handpiece is activated.
2. Never set bone screws with the handpiece in the “REAM” position. Only use the “SCREW” position for setting bone screws.

1. Twist the mode selector ring until the arrow is aligned with the arrow on the handpiece for the desired position.



2. Twist the direction control knob from “SAFE” to the desired operating direction (“FWD” or “REV”).



3. Depress the trigger to activate the handpiece.

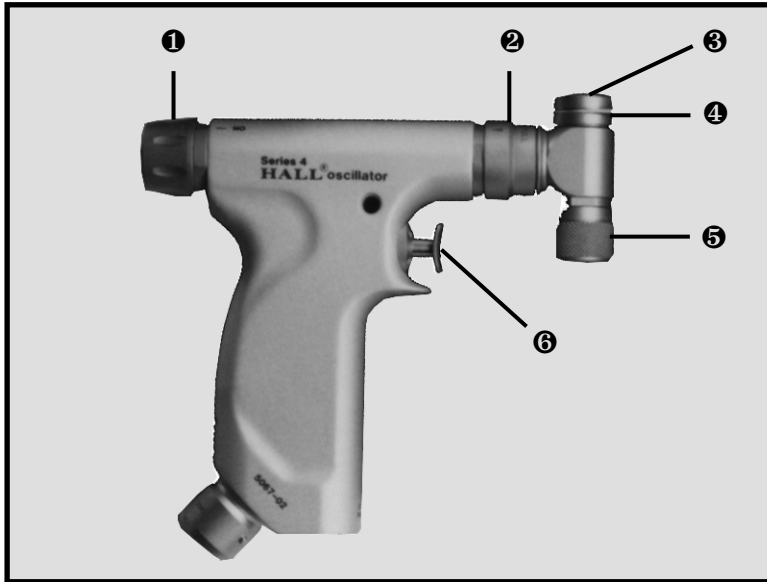

2.2.2 Oscillating Saw

- ❶ **Control Knob** - Place this knob in the “ON” position to activate the handpiece. Place in the “SAFE” position before changing blades, bits, accessories or hoses, and when the instrument is not in use.
- ❷ **Head Locking Collar** - Allows the rotating head to be rotated and locked in any of 12 positions.
- ❸ **Rotating Head** - Houses the cutting blade and rotates to any of 12 positions at 30° intervals for appropriate surgical access.
- ❹ **Blade Locking Collet** - Holds the blade in place.
- ❺ **Blade Locking Knob** - Locks the blade securely in place.
- ❻ **Activation Trigger** - Press to operate the handpiece when the control knob is in the “ON” position.

2.2.2.1 Blade Attachment Instructions

1. To affix a blade to the blade-locking collet*:
 - (a) Place the control knob in the “SAFE” position.



* U.S. Patent 5,265,343

- (b) Open the blade-locking collet by rotating the blade-locking knob in the direction of the arrow to the “OPEN” position.



- (c) Insert the blade at the desired angle and align the blade holes with the blade-positioning pins. Be sure that the proper saw blades are used with the collet. Micro Sagittal Saw Blades may not be used in the wrenchless collet, only Hall series 5071-xxx blades can be used.

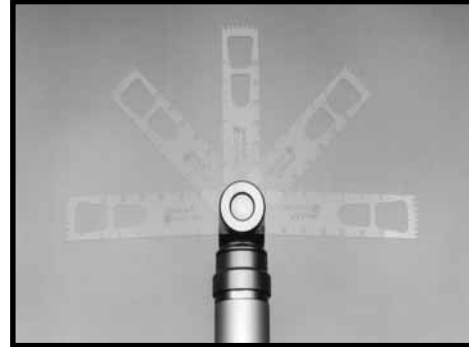

- (d) Rotate the blade locking knob to the closed position.

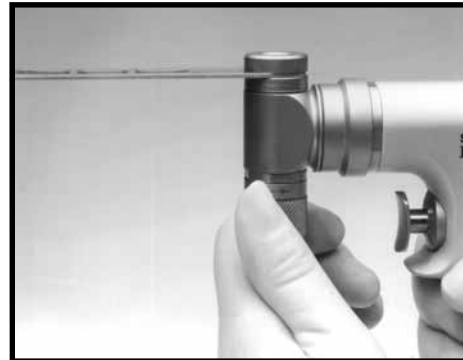

2.2.2.2 Rotating Head Instructions

1. The rotating head may be set in any of 12 positions at 30° intervals for appropriate surgical access. To change positions and cutting planes:

- (a) Grasp the head locking collar firmly and pull towards the back of the handpiece.

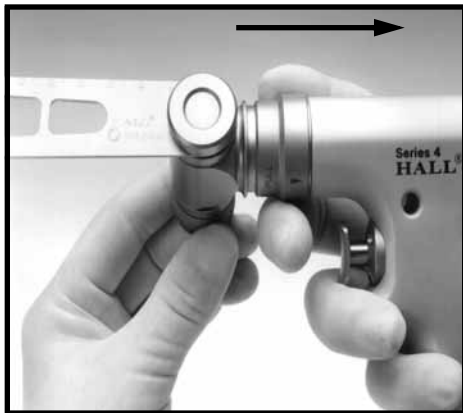

- (b) Rotate the head and blade to the desired position. Release the head locking collar.

2.2.2.3 Operating Instructions

1. To operate the handpiece:
 - (a) Twist the control knob from the “SAFE” position to the “ON” position:



- (b) Depress the activation trigger.

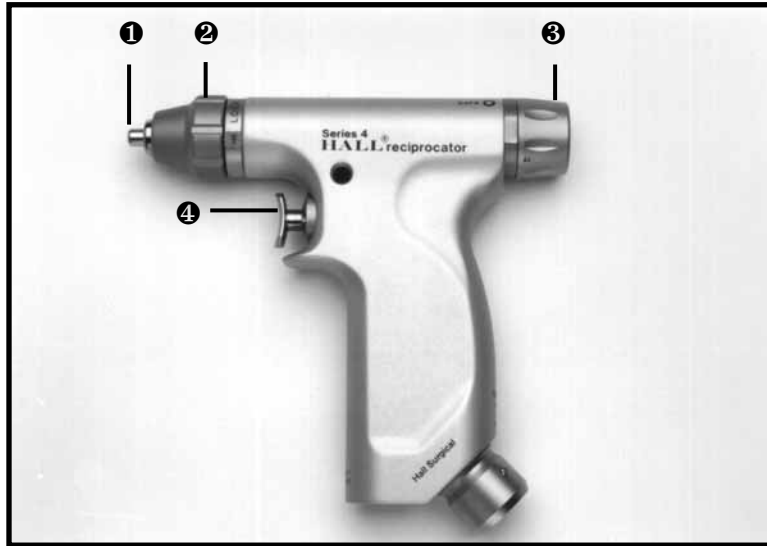

2.2.3 Reciprocating Saw

- ❶ **Blade Collet** - Holds the blade in place.
- ❷ **Collet Locking Knob** - Used to lock the blade collet.
- ❸ **Control Knob** - Place this knob in the “ON” position to activate the handpiece. Place in the “SAFE” position before changing blades, bits, accessories or hoses, and when the instrument is not in use.
- ❹ **Activation Trigger** - Press to operate the handpiece when the control knob is in the “ON” position.

2.2.3.1 Blade Attachment and Operation Instructions

1. To affix a blade to the handpiece:
 - (a) Place the control knob in the “SAFE” position.



- (b) Open the blade collet by turning the collet locking knob clockwise for adequate blade width.
- (c) Insert the shank of the blade into the slot and seat completely.



- (d) Blades may be locked in any position. Four (4) detents are provided for accurate 90° positioning. Before locking the collet, grasp the blade at the base of the collet and turn to the desired position.



- (e) Turn the collet locking knob counter-clockwise to firmly secure the blade.

2. To operate the handpiece:

- (a) Twist the control knob from the "SAFE" position to the "ON" position.



- (b) Depress the activation trigger.

2.2.4 Trauma Drill

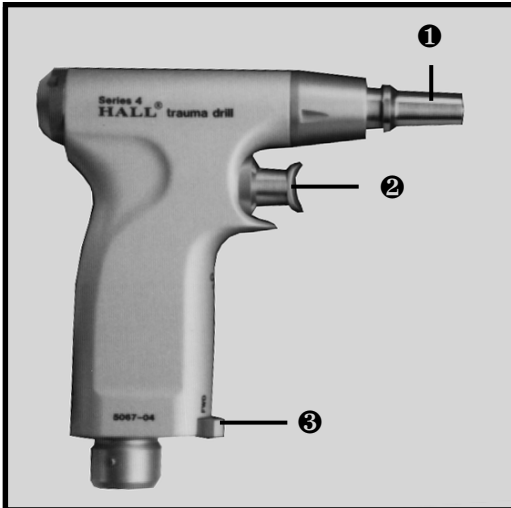

- ❶ **Combination Trinkle/AO Collet** - Accepts the various Trinkle and AO shank accessories.
- ❷ **Safety/Activation Trigger** - Rotate either left or right to the “SAFE” position when attaching/removing attachments, accessories and hoses. Rotate to the vertical position to activate the handpiece.
- ❸ **Direction Control Lever** - Used to select the operating direction between “FWD” (forward) “SCREW” and “REV” (reverse).

2.2.4.1 Connecting Attachments

1. Place handpiece in the “SAFE” position.
 - (a) Rotate the trigger either left or right.



Attachment of Trinkle Shank Accessories:

1. Pull back the outer collet sleeve.
2. Insert the Trinkle shank into the collet. The spring-loaded inner sleeve will retract.



3. Release the collet sleeve.



4. Once the shank has been totally inserted, rotate the accessory until it becomes completely engaged. Pull the accessory firmly to ensure proper engagement.
5. To remove the accessory, pull back the outer sleeve and pull the accessory out.

Attachment of AO Drill Accessories:

1. Align the flat portion of the accessory shank with the black arrow on the collet sleeve, and insert the accessory into the collet.
2. Insert the shank as far as it will go without pulling back the collet sleeve. Twist the shank to make sure it is aligned properly. If it is, it will not spin in the collet.
3. Pull back on the collet sleeve while pushing the shank further into the collet.

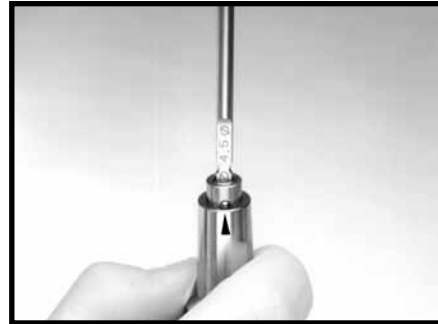

4. Release the collet sleeve. The shank is now locked into the collet. Pull the accessory firmly to ensure proper engagement.



5. To remove the accessory, pull back the outer sleeve and pull the accessory out.

2.2.4.2 Mode Selection and Activation

1. To select the desired mode, move the direction control lever on the bottom of the handpiece to the desired position.



NOTE: This can be done using the small finger while holding the instrument.



2. To select the “SCREW” mode, place the direction control lever in the center (there is a detent). This automatically limits the torque in the forward mode to 18-22 in. lbs. for setting bone screws.



3. To operate the handpiece, depress the trigger.

3.0 MAINTENANCE

3.1 Cleaning and Sterilizing

3.1.1 Care and Cleaning Precautions

1. Never immerse handpieces or attachments.
2. Never clean handpieces with liquid or chemical disinfectants.
3. Never clean handpieces in an ultrasonic cleaner or combination washer/sterilizer.
4. Never sterilize or immerse the regulator in any solution.
5. Steam sterilize only (except regulator). Follow instructions starting on page 21.
6. Do not lubricate any of the handpieces or accessories.

3.1.2 Cleaning Instructions

NOTE: Care should be taken to keep the nose of the handpieces pointed down while cleaning and rinsing.

1. Remove attachments and accessories from the handpiece.
2. With the hose attached, thoroughly scrub the handpiece and attachments with a soft brush and mild detergent. For attachments, use a nylon brush or pipe cleaner and clean the insides thoroughly. Remove all traces of blood, coagulated material, stains, etc. **DO NOT IMMERSE** handpieces or attachments in soap solution or rinse water.
3. Keeping the nose of the handpiece pointed downward, and with the hose still attached, rinse under running water to remove all traces of soap. Flush the surfaces free of tap water with distilled water to prevent metal discoloration.
4. Shake the handpiece and attachments free of water and wipe the surfaces with a clean, lint-free towel.
5. Clean the cutting surfaces of reusable blades and bits with a mild detergent and a brush. Examine the cutting surfaces to ensure complete removal of any blood, bone chips, etc. Rinse off all traces of soap with running water. **DO NOT IMMERSE**.
6. Detach the hose prior to sterilization.

3.1.3 Sterilization

Steam sterilization is safe and effective, and there are no contraindications for sterilizing Hall instruments, attachments and accessories.

Ethylene Oxide Gas sterilization is not recommended for powered surgical instruments, as gas is used primarily for heat sensitive products.

NOTES:

1. **“Flash” sterilization should not be used for powered surgical instruments as internal sterilization of equipment is required between cases.**
2. **The following guidelines do not guarantee the device is sterile after the procedure. Your institution is still responsible for the normal sterility assurance validation.**
3. **Additional drying time may be required for complete heat and moisture dissipation. Operation of a handpiece that is not completely cool or dry may decrease performance and/or reliability.**

WARNING: Use of disinfecting solutions for an exterior instrument wipe will not sterilize the instrument, and cannot be recommended.

1. Place the cleaned instruments in an instrument tray.
2. Remove the hose from the handpiece. Do not crimp the hose when closing the lid.

3. If instruments are to be wrapped, two double thicknesses of #140 thread count wrappers should be utilized. Do not use Tyvek bags, as they retain moisture and may damage the handpiece. Exposure times are the same for wrapped or unwrapped instruments.
4. Do not immerse in liquid to cool. Cool by exposure to room temperature. Do not cover with a wet towel.
5. Do not run handpiece while warm. Allow adequate time for handpiece to cool prior to surgery.

3.1.3.1 Pre-Vacuum Steam Sterilization

If your pre-vacuum steam sterilizer has a pre-fixed cycle, use the hard goods cycle.

If it does not have a pre-fixed cycle:

Temperature: 270°-272°F (132°-133°C).

Exposure time: 4 minutes

Drying time: 8 minutes minimum

Wrapped or unwrapped

3.1.3.2 Gravity Air Displacement Steam Sterilization

Temperature: 270°-272°F (132°-133°C).

Exposure time: 35 minutes

Temperature: 250°-254°F (121°-123°C).

Exposure time: 60 minutes

Drying time: 8 minutes minimum

Wrapped or unwrapped

* For Sterilization Containers with filters, add **FIVE (5)** minutes to the Gravity cycle.

NOTE: Dry times are extremely important for reliability and durability of handpieces.

If eight minutes in your autoclave does not completely dry the handpiece, additional dry time is recommended.

3.2 Troubleshooting

Table 1: Troubleshooting Guide		
Symptom	Possible Cause	Corrective Action
Drill/Reamer Handpiece		
Lack of handpiece power.	<ul style="list-style-type: none"> ◆ Regulator malfunction. ◆ Operating pressure incorrect. ◆ Hose not fully or properly seated in regulator, handpiece and/or foot control. ◆ Restrictions in hose. ◆ Tank pressure below 500 psi. ◆ Tank valve not completely open. ◆ Ensure nitrogen is being used. ◆ Mode selector ring is not in the proper position for the operation being performed. 	<ul style="list-style-type: none"> ◆ Run handpiece on another regulator to see if the problem is the handpiece or regulator. Replace appropriate piece of equipment. ◆ Set pressure to recommended operating pressure. ◆ If using a hose longer than 10 ft. or an extension hose is being used, add an additional one psi of pressure per each additional foot of hose. ◆ Check all hose connections and ensure they are completely seated. ◆ Remove any hose restrictions. ◆ Do not start procedure if tank pressure is below 500 psi. Replace tank. ◆ Completely open tank valve. ◆ Compressed air (especially if contaminated) may reduce performance. ◆ Assure the mode selector ring is in the proper operating position.

Table 1: Troubleshooting Guide		
Symptom	Possible Cause	Corrective Action
Drill/Reamer Handpiece (Continued)		
Handle gets hot during use.	◆ Operating pressure incorrect.	◆ Set pressure to recommended operating pressure.
Handpiece ratchets while drilling or reaming.	◆ Mode selector ring positioned in "SCREW" mode.	◆ Place mode selector ring completely in the "DRILL" or "REAM" mode.
Mode selector ring will not shift from "DRILL" to "REAM" or "REAM" to "DRILL".		◆ With the direction control knob in the "FWD" position, place the mode selector ring in whichever position it will easily go into. Briefly activate the handpiece. Shift the mode selector ring to the desired position.
Motor operates, but the output shaft does not.	◆ Direction control knob in the "SAFE" position.	◆ Place the direction control knob in either the "FWD" or "REV" position.

Table 1: Troubleshooting Guide		
Symptom	Possible Cause	Corrective Action
Trauma Drill		
AO attachment will not seat completely.	◆ Flat side of attachment is not aligned with the arrow on the collet.	◆ Align the flat side of attachment with the arrow on the collet.
Trinkle attachment will not seat completely.	◆ Detent on attachment is not aligned with the arrow on the collet.	◆ Align detent of attachment with the arrow on the collet.
Handpiece stalls while driving.	◆ Direction control lever possibly in the “SCREW” position.	◆ Place the direction control lever in the “FWD” or “REV” position.
Lack of handpiece power.		◆ See Drill/Reamer troubleshooting information on the previous pages.

Table 1: Troubleshooting Guide		
Symptom	Possible Cause	Corrective Action
Reciprocating and Oscillating Saws		
Reciprocator blade will not seat in the collet.	<ul style="list-style-type: none"> ◆ Collet locking knob not loose. 	<ul style="list-style-type: none"> ◆ Loosen the collet locking knob and try seating the blade again.
Reciprocator blade collet will not properly close on blade.	<ul style="list-style-type: none"> ◆ Blade is not in a positive detent hold. ◆ Blade is not fully seated. 	<ul style="list-style-type: none"> ◆ Place blade in a positive detent position. ◆ Completely seat blade in collet.
Control knob will not go into the “SAFE” position.		<ul style="list-style-type: none"> ◆ With a light pressure, pull the trigger out to its stop. Rotate the control knob to the “SAFE” position. Do not force.
Lack of handpiece power.		<ul style="list-style-type: none"> ◆ See Drill/Reamer troubleshooting information on the previous page.

3.3 Specifications

Linvatec Corporation is certified by TÜV Product Service to EN ISO 9001 and EN 46001, and to the Medical Device Directive 93/42/EEC with certificates for Annex II, Clause 3; Annex II, section 4; and Annex V.

3.3.1 Drill/Reamer Handpiece

Operating Speed (forward and reverse):

Drill Position: 750 rpm

Screw Position: 250 rpm

Ream Position: 250 rpm

Average Output Torque (forward and reverse):

Drill Position: 40 in. lbs.

Screw Position: 18-22 in. lbs. (Automatic torque limiter)

Ream Position: 100 in. lbs.

Weight: 39.7 oz. (1.13 kg)

Operating Pressure: 100 psi running (7 kg/cm²)

Recommended Power Source: Medical grade, water-pumped, compressed dry nitrogen

Consumption: 13.0 cfm, maximum (368 L/min)

3.3.2 Trauma Drill Handpiece

Operating Speed:

Drill Position (forward and reverse): 250 rpm

Screw Position (forward only): 250 rpm

Average Output Torque:

Drill Position (forward and reverse): 40 in. lbs.

Screw Position (forward only): 18-22 in. lbs. (Automatic torque limiter)

Weight: 28.8 oz. (816 g)

Operating Pressure: 100 psi running (7 kg/cm²)

Recommended Power Source: Medical grade, water-pumped, compressed dry nitrogen

Consumption: 17.0 cfm, maximum (481 L/min)

3.3.3 Oscillating Saw

Operating Speed: 14,000 Cycles/minute (nominal)

28,000 Strokes/minute (nominal)

Oscillation: 5° Arc

Blade Rotation: 12 positions @ 30° intervals

Weight: 33.8 oz. (967.6 g)

Operating Pressure: 100 psi running (7 kg/cm²)

Recommended Power Source: Medical grade, water-pumped, compressed dry nitrogen

Consumption: 13.0 cfm, maximum (368 L/min)

3.3.4 Reciprocating Saw

Operating Speed:	17,000 Cycles/minute (nominal) 34,000 Strokes/minute (nominal)
Stroke:	0.125 inch (3.2 mm)
Blade Rotation:	May be locked in any position. 90° angles marked with detents
Weight:	29.6 oz. (847.4 g)
Operating Pressure:	100 psi running (7 kg/cm ²)
Recommended Power Source:	Medical grade, water-pumped, compressed dry nitrogen
Consumption:	13.0 cfm, maximum (368 L/min)

3.3.5 Environmental Requirements

Operating:	
Ambient Operating Temperature:	+ 50°F to 77°F (+ 10°C to + 25°C)
Relative Humidity:	30% to 75%
Atmospheric Pressure:	700hPa to 1060 hPa
Storage:	
Ambient Temperature:	- 40°F to + 158°F (- 40°C to + 70°C)
Relative Humidity:	10% to 100%
Atmospheric Pressure:	500hPa to 1060 hPa

NOTE: There are no toxic components used in the manufacture of the Series 4 handpieces and attachments. After the useful life of the product, dispose of components and service parts properly.

4.0 CUSTOMER SERVICE and WARRANTY

4.1 Customer Service

If you need technical assistance regarding the use or application of this product, or you encounter a problem that requires servicing or repair, contact Linvatec Customer Service at 800-925-4255 or your local Hall Surgical Sales Representative. Outside the U.S. contact your local Linvatec Hall Representative.

Report any events involving injuries or malfunctions to the Linvatec Regulatory Affairs Department.

Returning products for any reason requires a Return Goods (R.G.) number that can be obtained by contacting Linvatec Customer Service. Please provide the following information:

- Product Number
- Serial Number
- Reason for Return
- Original Invoice Number
- Date of Purchase

Repairs

Products returned for repair must have an authorized Return Goods (R.G.) number prominently displayed on the box and included on all paperwork. Refer to this number if making inquiries about the repair status. Please call Linvatec Customer Service and provide the following information to obtain an R.G. number prior to returning any product for repair:

- Product Number
- Serial/Lot Number - if applicable
- Original Invoice Number
- Date of Purchase
- Detailed description of the problem

If you require a quote - Notify Customer Service when requesting your R.G. number, or on the paperwork returned with the product indicate that a quote is required. If a quote is not requested the repair will be processed and your account billed accordingly - provided the repair is not covered under warranty.

Minimum repair charge - There is a minimum repair charge (except for products covered under warranty). This charge also applies to products returned for repair in which a problem cannot be verified.

Whenever it is required to return your product for repairs, be sure to package it in a protective carton. We recommend that you save the original shipping container for this purpose. In-transit damage is not covered by the warranty, therefore, it is best to always insure shipments.

Returned Goods

Products must be returned within 45 days of ship date. Returned products are subject to a restocking fee of fifteen percent (15%) of the purchase price (minimum charge \$25). Products returned as a result of errors attributable to Linvatec are exempt from this fee.

Returns must have an authorized Return Goods (R.G.) number prominently displayed on the box and included on all paperwork.

Returns must be shipped prepaid freight, otherwise they will not be accepted. Products must be decontaminated and sterilized before returning. Those contaminated with biohazardous materials will be immediately returned to you for decontamination and sterilization.

Linvatec

**Attn.: Customer Service Dept.
11311 Concept Boulevard
Largo, Florida 33773-4908 USA**

Customer Service

(within U.S.)

Phone: 800-925-4255

FAX: 727-399-5256

(outside U.S.)

Phone: 727-392-6464

FAX: 727-397-4540

Linvatec Regulatory Affairs

(within U.S.)

Phone: 800-237-0169

(outside U.S.)

Phone: 727-399-6620

4.2 Attachments and Accessories

Drill/Reamer Handpiece

<u>REF</u>	<u>Description</u>
5067-001	Drill/Reamer (Includes: Trinkle Adaptor and Universal Hose)
5067-091	Drill/Reamer without Hose (Includes: Trinkle Adaptor)
5044-004	Torque Control Handle
5044-005	Series 3 & 4 Trinkle Adaptor
5044-006	Series 3 & 4 AO Adaptor
5044-009	Series 3 & 4, 5/32 inch to Jacobs Adaptor
5044-011	Series 3 & 4, 1/4 inch to Jacobs Adaptor
1365-042	Zimmer to Hudson Adaptor
1384-028	Zimmer to Trinkle Adaptor
1384-029	Zimmer to 1/4 inch Jacobs Adaptor
1384-034	Zimmer to AO Adaptor
1384-073	Zimmer to Stryker Adaptor
5052-020	Two-Way Pin Driver (Zimmer)

Oscillating Saw

<u>REF</u>	<u>Description</u>
5067-002	Oscillator (Includes: Universal Hose)
5067-092	Oscillator without Hose

Reciprocating Saw

<u>REF</u>	<u>Description</u>
5067-003	Reciprocator (Includes: Universal Hose)
5067-093	Reciprocator without Hose

Trauma Drill

<u>REF</u>	<u>Description</u>
5067-004	Trauma Drill (Includes: Universal Hose)
5067-094	Trauma Drill without Hose
1368-005	Trinkle to 5/32 inch Jacobs Adaptor
1368-010	Trinkle to 1/4 inch Jacobs Adaptor
5040-011	Wiredriver Attachment
5052-019	Two-Way Pin Driver-Trinkle
5053-123	Wire Guard
5053-124	Cleaning Brush

Miscellaneous Handpiece Accessories

<u>REF</u>	<u>Description</u>
5052-010	Universal Hose
5067-501	Extended Warranty (U.S. only)

4.3 Linvatec and Hall® Surgical Instrument Warranty

Linvatec Corporation, (“the Company”), warrants to the first purchaser or lessee (“Customer”) that Linvatec and Hall Surgical instruments, attachments and parts manufactured by or for the Company (hereinafter collectively “Instruments”) have been tested, inspected, and shipped in proper working order.

The Company warrants all new Instruments to be free from defects in materials and workmanship for the following periods, measured from Customer’s receipt:

1. Powered Surgical Equipment (battery, electric, pneumatic) - Twelve (12) Months
2. Battery Chargers - Twelve (12) Months
3. Battery Packs - Three (3) Months
4. Burs and Blades - Upon receipt
5. Pneumatic Hoses - Six (6) Months
6. Handpiece Cords and Power Cords - Twelve (12) Months
7. Camera Consoles - Twenty-four (24) Months
8. Video Components - Twelve (12) Months
9. Video Cables and Light Guides - Three (3) Months
10. Non-autoclavable Camera Heads - Twelve (12) Months
11. Autoclavable Camera Heads - 500 use service program (prorated credit after 250 uses)

12. Shutt SLG Instruments - Lifetime
13. Shutt Non-SLG Instruments - Twelve (12) Months
14. Footswitches - Twelve (12) Months
15. Irrigation Systems - Twelve (12) Months
16. Reusable Procedure Specific Instruments - Twelve (12) Months

Linvatec recommends that the Hall Series 4 Handpieces and pneumatic regulators described in this manual be returned to the factory for routine maintenance every twelve (12) months.

Failure to follow this routine maintenance schedule may result in damage to the handpiece and may invalidate the product warranty.

The Company warrants to the Customer that any service or repair work performed by the Company on Instruments not within the warranty period shall be free from defects in workmanship and materials for a period of six (6) months after the date the Customer receives the Instrument(s). This limited warranty applies only to the actual service or repair work performed by Company service representatives. The Company warrants that all parts and assemblies used in the repair or service of Instruments meet new part functional specifications, although some parts or assemblies may have been remanufactured.

All parts and assemblies replaced by the Company under warranty shall become the property of the Company.

If within the specified warranty period the Customer discovers that an Instrument has a defect in material and/or workmanship, it must promptly notify the Company. If it becomes necessary to return the Instrument to the Company, the Customer must (a) acquire a "Returned Goods" authorization from the Company Customer Service, (b) pack the unit carefully, and (c) return it to the Company via air freight, prepaid.

Within a reasonable time after receipt of Instrument, the Company will investigate and shall correct any defect covered by warranty by providing, at its option, one of the following: service or repair of the Instrument, a replacement of the Instrument, or a refund of the purchase price of the Instrument. These remedies are the Customer's exclusive remedies under this warranty.

The foregoing limited warranties do not apply to:

1. Instruments which have been tampered with, altered, abused or misused.
2. Instruments damaged through use with other than Company authorized accessories, attachments, burs or blades.
3. Instruments not manufactured by or for the Company.
4. Instruments used for purposes other than those for which they were designed and manufactured, including use in any way inconsistent with the instructions and warnings contained in the Company instruction manuals and package inserts.
5. Instruments which were last serviced, refurbished, reprocessed or reconditioned by a nonauthorized service entity.

6. Instruments which did not have their aforementioned routine maintenance schedule followed.

The foregoing limited warranties are in lieu of all other warranties, expressed or implied, including, but not limited to, the implied warranties of merchantability and fitness for a particular purpose.

Except claims for personal injury, in no case shall the Company be liable for any special, incidental or consequential damages based upon breach of warranty or any other legal theory. Some jurisdictions do not allow limits on warranties, or on remedies, and, in such jurisdictions, the limits in this and the preceding paragraphs may not apply.

The Company reserves the right (a) to make design changes to Instruments at anytime without notice to Customer and without incurring any obligation to incorporate those changes into Instruments previously purchased or leased, and (b) to make changes from time to time in the contents of any publication, instruction manual or package insert without any obligation to notify Customers of such revisions or changes.



11311 Concept Boulevard Largo, Florida 33773-4908

Phone: (727) 392-6464

Customer Service: (800) 925-4255

USA Fax: (727) 399-5256

International Fax: (727) 397-4540

www.linvatec.com

© 2000 Linvatec Corporation, a subsidiary of ConMed Corporation



All rights reserved. Printed in USA W41-033-004 Rev. A 01/2000