

Mini-Driver™ Air Instrument System

3M

ASSEMBLY AND MAINTENANCE

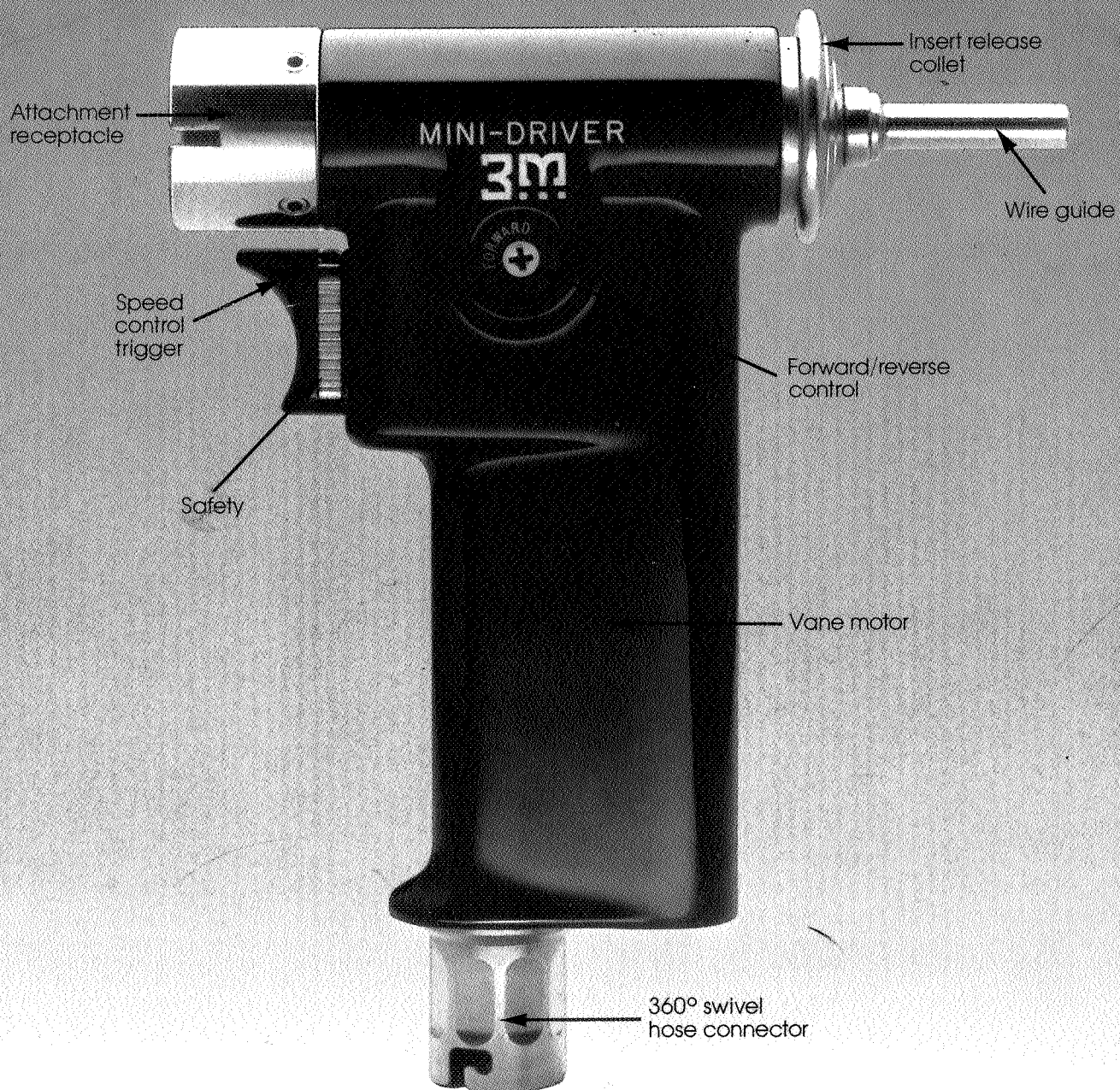

SPECIFICATIONS

Cat. No.	K100
Normal operating pressure	100 psi
Variable speed	up to 1250 rpm
Nitrogen consumption	4.5 scfm
Weight	482g (17 oz)

Mini-Driver™ BRAND Air Instrument System

3M
COMPANY

HOSE AND HANDPIECE

HOSE

ASSEMBLY

Male Schrader fitting.
Connect to female Schrader fitting at nitrogen regulator by pushing fittings together.

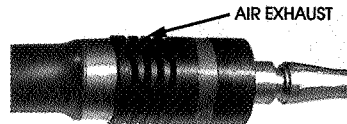

Male instrument fitting.

Make certain O-ring is in place before connecting to MINI-DRIVER handpiece.

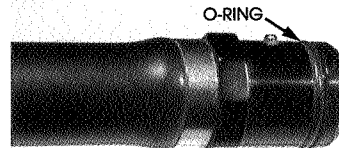

HANDPIECE

ASSEMBLY

Activate safety.
Make certain O-ring is in place on hose.
Attach hose to MINI-DRIVER swivel connector.

Set forward/reverse control to desired position.

Forward—control button pushed in on left side.

Reverse—control button pushed in on right side.

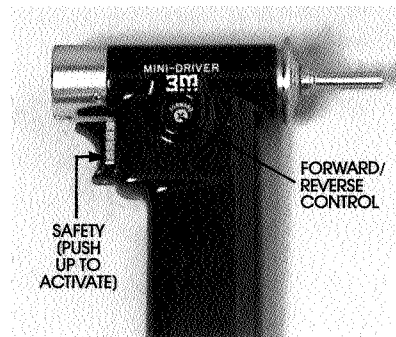

HANDPIECE

MAINTENANCE

CLEANING

- DO NOT** immerse instrument in any liquid.
 - DO NOT** clean instrument in ultrasonic cleaners.
 - DO NOT** place instrument in combination washer-sterilizers.
 - USE ONLY 3M Brand** lubricants and cleaners.
- Take instrument to clean-up room immediately after surgical procedure.

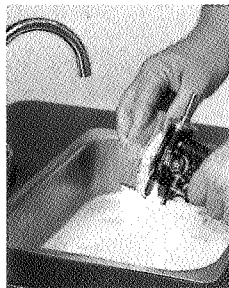
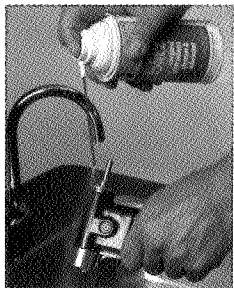

Remove debris by spraying Blitz Surgical Instrument Cleaner and Lubricant over all exposed surfaces and scrub with soft bristle brush, or use mild detergent and warm water and scrub with soft bristle brush. All traces of blood, coagulated material, etc., should be completely removed. **DO NOT ALLOW WATER TO ENTER INTERNAL PARTS.** Shake off excess. Wipe dry with soft cloth.

LUBRICATION

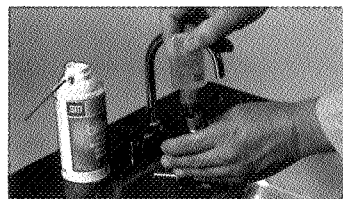

Depress throttle and place three drops of M317 Air Instrument Lubricant into rear standpipe. Do not use Blitz cleaner to lubricate motor.

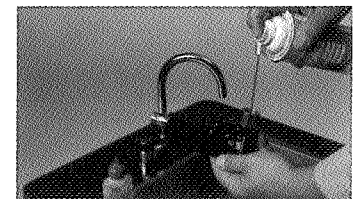

Blitz cleaner must be used to clean and lubricate nosepiece collet. Move forward/reverse control to insure operation.

Wipe hose with soft towel moistened with Blitz cleaner or mild soap solution. Lubricate end connectors with Blitz cleaner and lubricant. Connect handpiece to dry nitrogen source and run at full speed (100-110 psi) for five seconds to disperse lubricant through bearings.

Mini-DriverTM BRAND Air Instrument System



K111 SWANSON K-WIRE CHUCK ASSEMBLY

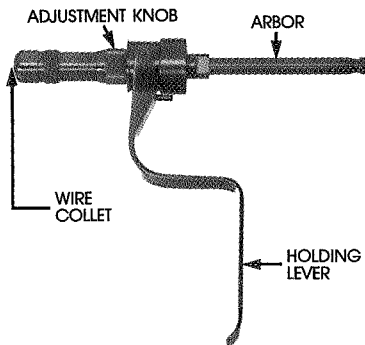

Swanson K-wire chuck attachment.

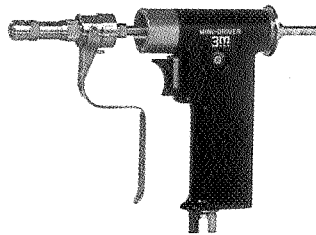

Insert arbor of attachment into MINI-DRIVER handpiece.

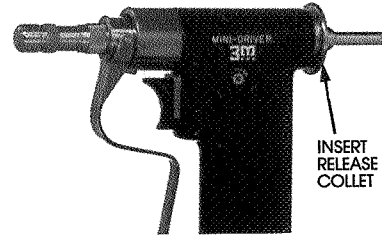

Press insert/release collet and push attachment into position. Release insert/release collet.

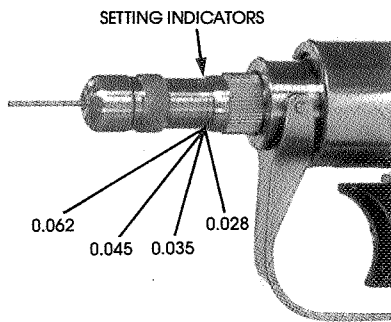

Turn knurled adjustment knob to approximate setting to accept wire or pin. K111 attachment will accept wires and pins from 0.028 through 0.062 inches.

Insert wire or pin.

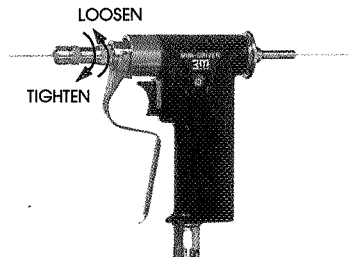

Tighten adjustment knob until wire is secure. Turn adjustment knob between two and three complete revolutions to open collet, which sets automatic tension adjustment.

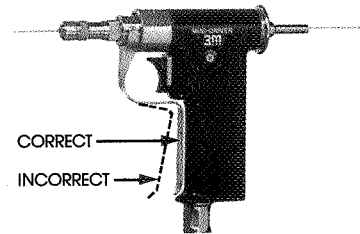

When K111 is properly adjusted, the holding lever will be parallel to hand-piece when lever is fully depressed.

Activate MINI-DRIVER unit by releasing safety and pressing throttle trigger while depressing K111 holding lever. Release holding lever to move wire or pin.

Remove attachment from MINI-DRIVER handpiece.

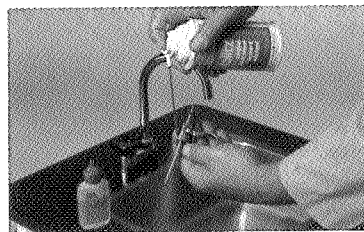

Remove debris by spraying Blitz cleaner liberally over all exposed surfaces. All traces of blood, coagulated material etc., should be completely removed. Wipe dry with soft cloth.



Spray Blitz cleaner liberally into nosepiece. Make certain to shake out all excess fluid before wiping dry.

MAINTENANCE

DO NOT immerse in any liquid.
DO NOT clean in ultrasonic cleaners.
DO NOT place in combination washer-sterilizers.
USE ONLY 3M Brand lubricants and cleaners.

Mini-DriverTM BRAND Air Instrument System

3M
COMPANY

K120 SAGITTAL SAW ATTACHMENT ASSEMBLY

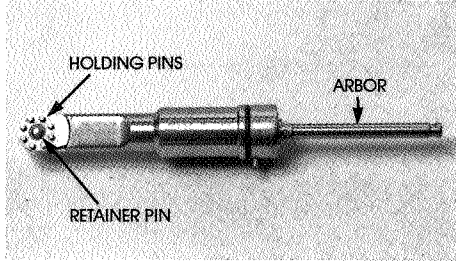

K120 Sagittal Saw Attachment

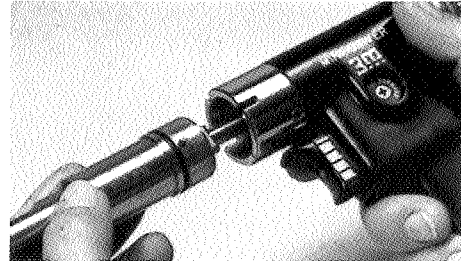

Insert arbor of sagittal saw into MINI-DRIVER handpiece.

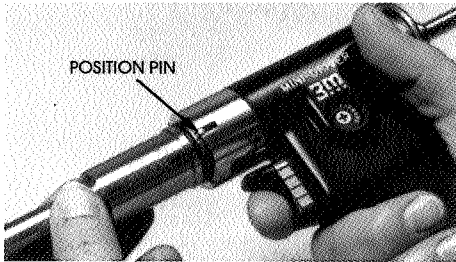

Guide the position pin into one of the four available slots in the insert collet.



Press insert/release collet and push sagittal saw into position. Release the insert/release collet to secure sagittal saw.

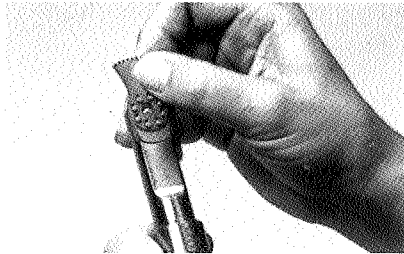

Select appropriate blade for the surgical procedure. Position the blade in the desired position over the holding pins. Five positions are available.

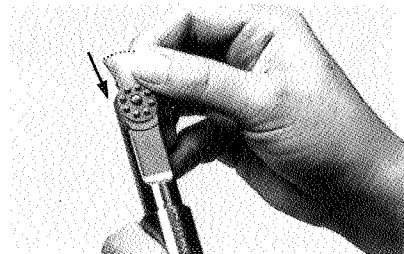

To secure blade, press blade down onto the holding pins and push to allow center retaining pin to pop up to lock the blade in place.

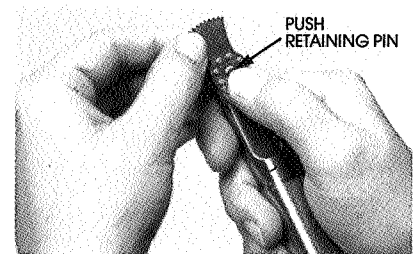

To release blade, push center retaining pin, pull blade forward and lift off holding pins.

MAINTENANCE

DO NOT immerse attachments in any liquid.

DO NOT clean attachments in ultrasonic cleaners.

DO NOT place attachments in combination washer-sterilizers.

USE ONLY 3M Brand lubricants and cleaners.

CLEANING

Remove attachment from MINI-DRIVER handpiece. Spray Blitz cleaner liberally over exposed surfaces to remove debris or use mild soap solution. Shake out excess cleaner and wipe dry. If Blitz cleaner is used, no lubrication is needed.

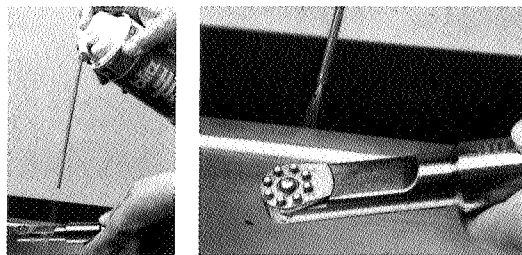

LUBRICATION

If soap solution is used to clean attachment, spray Blitz cleaner onto exposed surfaces and apply one drop of M317 Lubricant beneath holding pin plate.

Mini-Driver™ BRAND Air Instrument System

3M
CORPORATION

K110 JACOBS CHUCK
K112 TRINKLE CHUCK
K113 HUDSON CHUCK
ASSEMBLY

Insert arbor of attachment into MINI-DRIVER handpiece. Rotate attachment until fully seated.

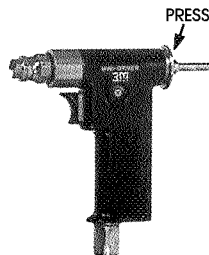
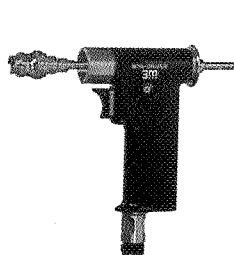

Press insert/release collet and push attachment into position. Release insert/release collet. To release attachment, press insert/release collet and pull insert out of handpiece.

K110 5/32" Jacobs Chuck Insert

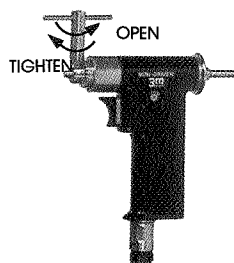
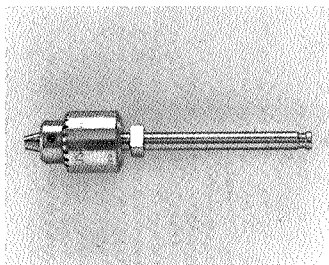

Open Jacobs chuck by inserting D298 chuck key and turning counterclockwise. Insert pin, wire or bur. K110 will accept pins up to 5/32" in size. Tighten chuck by inserting chuck key and turning clockwise.

K112 Trinkle Chuck Insert
The K112 is designed with a trinkle fitting to accept all accessories with a trinkle end.

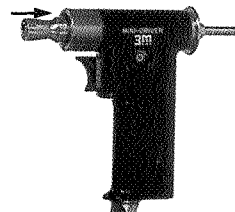
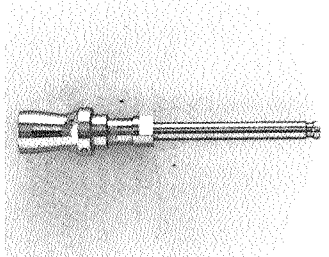

Pull back sleeve of trinkle fitting to insert accessory.

K113 Hudson Chuck Insert
The K113 is designed with a Hudson fitting to accept all accessories with a Hudson end.

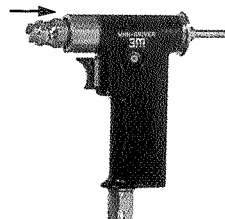
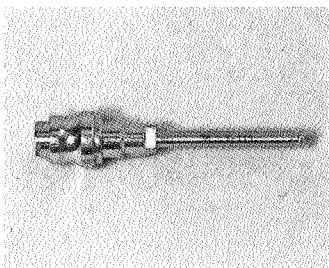

Pull back sleeve of Hudson chuck to insert appropriate accessory.

MAINTENANCE

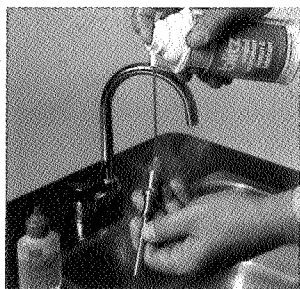

Use only 3M Brand lubricants. Inserts can be cleaned in ultrasonic cleaners.

Remove debris by spraying Blitz cleaner liberally over all exposed surfaces and scrub with soft bristle brush, or use mild detergent and warm water and scrub with soft bristle brush. All traces of blood, coagulated material, etc. should be completely removed. Shake off excess. Wipe dry with soft cloth.

If Blitz cleaner is not used to clean attachment, place one drop of M317 lubricant on end of insert and move sleeve (rotate Jacobs chuck).

Mini-Driver™ BRAND Air Instrument System

3M
CORPORATION

D520, D524 AUTOMATIC SCREWDRIVERS

ASSEMBLY

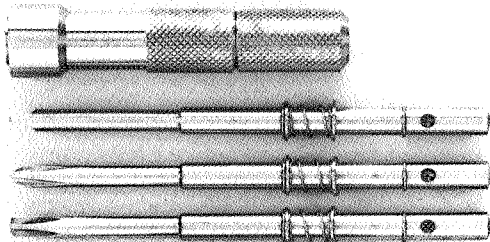

Select proper bit for the procedure:
D521 Slotted bit
D522 Cruciata bit
D523 Phillips bit
Use with D520 Screwdriver

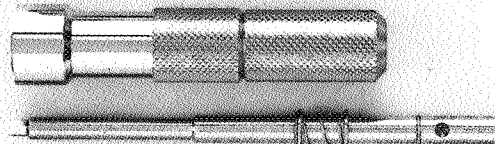

D525 Hex bit (use only with D524 Screwdriver)

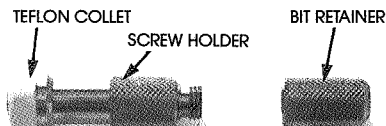

Disassemble screwdriver

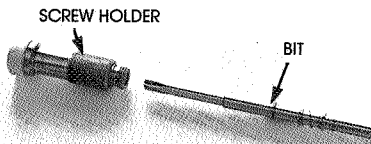

Insert bit into the screw holding mechanism, tip first.

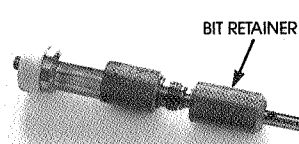

Slide bit retainer over blunt end of bit and secure by turning retainer clockwise until tight.

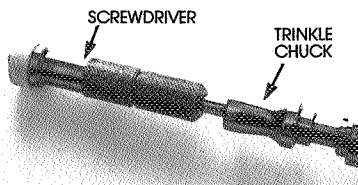

Insert trinkle chuck into MINI-DRIVER handpiece. Insert screwdriver into trinkle chuck.

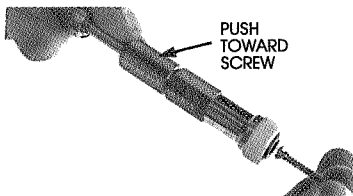

To engage screw in the holding mechanism, hold screw firmly in one hand. Engage screwdriver bit into screw head, and while holding grooved portion of screwdriver body, push screwdriver body firmly toward screw until holder snaps forward and grasps screw head.

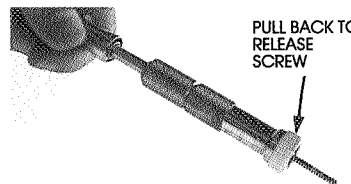

To manually release screw, pull back on teflon collar.

MAINTENANCE

DO NOT immerse attachments in any liquid.

DO NOT clean attachments in ultrasonic cleaners.

DO NOT place attachments in combination washer-sterilizers.

USE ONLY 3M Brand lubricants and cleaners.

Remove debris by spraying Blitz cleaner liberally over all exposed surfaces and scrub with soft bristle brush, or use mild detergent and warm water and scrub with soft bristle brush. All traces of blood, coagulated materials, etc. should be completely removed. Shake off excess. Wipe dry with soft cloth.

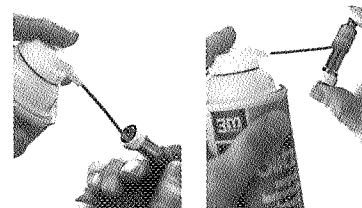

Spray Blitz cleaner into endpiece and around edges of screw holder.

Mini-DriverTM BRAND Air Instrument System

3M
CORPORATION

Troubleshooting Guide

Symptoms	Possible Cause	Cure
MINI-DRIVER HANDPIECE		
Loss of speed and torque. Excessive noise and heat.	Forward/Reverse button not in full operating position. Foreign debris lodged in motor. Worn bearings. Lack of lubrication. Malfunctioning regulator.	Push button fully into position. Lubricate according to instructions. Return to Service Center if malfunctioning persists. Check regulator maintenance guide.
ALL INSERTS		
Do not lock in place.	Excessive internal debris in Driver. Insert bent.	Return to service center.
K111 SWANSON K-WIRE CHUCK		
Will not adjust to hold wires. Excessive noise or heat.	Internal debris. Possible immersion. Worn bearing, dry bearing.	Return to service center. Lubricate according to instructions. Return to Service Center if problem persists.
HOSE		
Leaking air at quick disconnect. Air leakage at center of connector (Driver end). Cuts or tears in hose.	Worn or missing O-ring. Debris around ball seal. Improper storage.	Replace O-ring. Order part 8026 from Service Center. Disconnect hose. Spray ball seal with Blitz cleaner while depressing ball. Reconnect hose. Depress ball to permit debris to be blown clear. Make certain hose is disconnected from instrument before placing in autoclave case. Do not pinch hose when placing in autoclave case. (Replace torn or cut hose.)

Mini-DriverTM

BRAND

Air Instrument System



RECOMMENDED STERILIZATION EXPOSURE TIMES (RSET)

Recommended Sterilization Exposure Times (RSET) Air Powered Surgical Instruments
(Includes Time Safety Factors)

Method of Sterilization	Recommended exposure for all combinations of wrapped, disassembled instruments
Ethylene Oxide *100% (Cold Cycle) *100% (Warm Cycle) ** 88%/12%	4 hours at 30°C (86°F) 90 min at 63°C (145°F) 150 min at 54°C (130°F)
Steam ***Gravity Displacement 250 ± 2° F 121 ± 1° C	80 minutes
***Gravity Displacement 272 ± 2° F 133 ± 1° C	55 minutes
**** Gravity Displacement (flash-unwrapped) 272 ± 2° F 133 ± 1° C	"Single procedure" Average single procedure load-30 minutes ***** larger loads-55 min
*****High Speed Vacuum 272 ± 2° F 133 ± 1° C	8 minutes
High Speed Vacuum (flash-unwrapped) 272 ± 2° F 133 ± 1° C	*****8 minutes (external sterilization only)

Important Note: All steam sterilization times represent exposure time only and not total cycle time.

*STERI-VAC Gas sterilizer Model 400 (3M Company)

**AMSCO Model Cryotherm Console (Steam/gas) Medallion Series

***AMSCO Manual Medallion Laboratory Sterilizer

****AMSCO gravity displacement flash unit in local hospital surgical area

*****AMSCO Vacumatic Model B

*****See referenced article for more detailed information on external sterilization

Reference: McGlothlen GO, Weida DA: Recommendations for EO Gas Sterilization of Air Powered Surgical Instruments: *AORN Jnl* 21:87-102, January 1975.